

ServSwitch Agility Dual with VNC™

Extend high-quality DVI video, digital audio and USB connections across your high speed network as well as the internet to achieve ultimate system flexibility.

This guide is an addendum to the ServSwitch Agility and Agility Dual user guide and provides extra details that are specific to the ServSwitch Agility Dual with VNC.



Trademarks Used in this Manual

Black Box and the Double Diamond logo are registered trademarks, and ServSwitch is a trademark, of BB Technologies, Inc.

Mac is a registered trademark of Apple Computer, Inc.

Linux is registered trademark of Linus Torvalds.

Windows is a registered trademark of Microsoft Corporation.

NetWare is a registered trademark of Novell, Inc.

Sun is a trademark of Sun Microsystems, Inc.

Unix is a registered trademark of UNIX System Laboratories, Inc.

BSD is a registered trademark of UUNet Technologies, Inc.

Any other trademarks mentioned in this manual are acknowledged to be the property of the trademark owners.

We're here to help! If you have any questions about your application or our products, contact Black Box Tech Support at **724-746-5500** or go to **blackbox.com** and click on "Talk to Black Box." You'll be live with one of our technical experts in less than 60 seconds.

Federal Communications Commission and Industry Canada Radio Frequency Interference Statements

This equipment generates, uses, and can radiate radio-frequency energy, and if not installed and used properly, that is, in strict accordance with the manufacturer's instructions, may cause interference to radio communication. It has been tested and found to comply with the limits for a Class A computing device in accordance with the specifications in Subpart B of Part 15 of FCC rules, which are designed to provide reasonable protection against such interference when the equipment is operated in a commercial environment. Operation of this equipment in a residential area is likely to cause interference, in which case the user at his own expense will be required to take whatever measures may be necessary to correct the interference.

Changes or modifications not expressly approved by the party responsible for compliance could void the user's authority to operate the equipment.

This digital apparatus does not exceed the Class A limits for radio noise emission from digital apparatus set out in the Radio Interference Regulation of Industry Canada.

Le présent appareil numérique n'émet pas de bruits radioélectriques dépassant les limites applicables aux appareils numériques de la classe A prescrites dans le Règlement sur le brouillage radioélectrique publié par Industrie Canada.

Instrucciones de Seguridad

(Normas Oficiales Mexicanas Electrical Safety Statement)

1. Todas las instrucciones de seguridad y operación deberán ser leídas antes de que el aparato eléctrico sea operado.
2. Las instrucciones de seguridad y operación deberán ser guardadas para referencia futura.
3. Todas las advertencias en el aparato eléctrico y en sus instrucciones de operación deben ser respetadas.
4. Todas las instrucciones de operación y uso deben ser seguidas.
5. El aparato eléctrico no deberá ser usado cerca del agua—por ejemplo, cerca de la tina de baño, lavabo, sótano mojado o cerca de una alberca, etc..
6. El aparato eléctrico debe ser usado únicamente con carritos o pedestales que sean recomendados por el fabricante.
7. El aparato eléctrico debe ser montado a la pared o al techo sólo como sea recomendado por el fabricante.
8. Servicio—El usuario no debe intentar dar servicio al equipo eléctrico más allá a lo descrito en las instrucciones de operación. Todo otro servicio deberá ser referido a personal de servicio cAgilityicado.
9. El aparato eléctrico debe ser situado de tal manera que su posición no interfiera su uso. La colocación del aparato eléctrico sobre una cama, sofá, alfombra o superficie similar puede bloquea la ventilación, no se debe colocar en libreros o gabinetes que impidan el flujo de aire por los orificios de ventilación.
10. El equipo eléctrico deber ser situado fuera del alcance de fuentes de calor como radiadores, registros de calor, estufas u otros aparatos (incluyendo amplificadores) que producen calor.
11. El aparato eléctrico deberá ser conectado a una fuente de poder sólo del tipo descrito en el instructivo de operación, o como se indique en el aparato.
12. Precaución debe ser tomada de tal manera que la tierra física y la polarización del equipo no sea eliminada.
13. Los cables de la fuente de poder deben ser guiados de tal manera que no sean pisados ni pellizcados por objetos colocados sobre o contra ellos, poniendo particular atención a los contactos y receptáculos donde salen del aparato.
14. El equipo eléctrico debe ser limpiado únicamente de acuerdo a las recomendaciones del fabricante.
15. En caso de existir, una antena externa deberá ser localizada lejos de las líneas de energía.
16. El cable de corriente deberá ser desconectado del cuando el equipo no sea usado por un largo periodo de tiempo.
17. Cuidado debe ser tomado de tal manera que objetos líquidos no sean derramados sobre la cubierta u orificios de ventilación.
18. Servicio por personal cAgilityicado deberá ser provisto cuando:
 - A: El cable de poder o el contacto ha sido dañado; u
 - B: Objetos han caído o líquido ha sido derramado dentro del aparato; o
 - C: El aparato ha sido expuesto a la lluvia; o
 - D: El aparato parece no operar normalmente o muestra un cambio en su desempeño; o
 - E: El aparato ha sido tirado o su cubierta ha sido dañada.

Contents

1. Specifications.....	6
2. Introduction	7
3. Installation.....	14
3.1 Mounting.....	14
3.2 Connections	14
3.2.1 VNC network link.....	14
3.2.2 Local video link(s).....	15
3.2.3 Local Audio Links	16
3.2.4 Local USB Link.....	17
3.2.5 Local AUX Port.....	18
3.2.6 Local Power In.....	19
3.2.7 High speed links.....	20
4. Configuration	22
4.1 System and Teaming ports: Initial configuration.....	23
4.2 The VNC port: Initial configuration	26
4.3 Initial configuration	28
4.4 Controls.....	29
4.5 Mouse Control.....	30
4.6 Advanced mouse configuration	31
4.7 Info	32
4.8 Power switching	32
4.9 Keyboard Control	33
4.10 Video settings	34
4.11 Editing the viewer window menu bar.....	35
4.12 Virtual Media	36
4.13 A rough guide to configuring local and remote units.....	40
4.14 Performing an upgrade	43
4.15 Options switches.....	44
5. Operation.....	45
5.1 Front Panel Indicators.....	45
5.2 Using the VNC viewer	46
6. Further information	48
Appendix A. Configuration menus (via VNC).....	49
Appendix B. VNC viewer window options.....	66
Appendix C. The KVMADMIN utility	67
Appendix D. Java viewer options	68
Appendix E. Hotkey sequences.....	70
Appendix F. Known working video modes	72
Appendix G. Mounting options	73
Appendix H. Fiber modules and cables	75
Appendix I. Safety Information	76

1. Specifications

ServSwitch Agility Dual with VNC

Casing (w x h x d):	198mm (7.92") x 44mm (1.76") x 145mm (5.7")
Construction:	1U compact case, robust metal design
Weight:	1.11kg (2.44lbs)
Mount kits:	Rack mount kits: Single (RMK2004) or dual units (RMK2004-2) per 1U slot. VESA monitor / wall mount chassis kit: RMKVESA
Input Power:	100-240VAC 50/60Hz, 0.8A,
Output Power:	5VDC 20W
Operating Temperature:	0°C to 40°C (32°F to 104°F)
Approvals:	CE, FCC

2. Introduction

Thank you for choosing the ServSwitch Agility Dual with VNC transmitter which represents a major advance in the capabilities of digital extenders and switches. By encoding high quality DVI video, digital audio and USB connections into Internet Protocol (IP) messages, Agility Dual with VNC offers very flexible signal switching and distribution capabilities.

Our extensive knowledge of interfacing techniques and high speed networking has allowed us to develop new ways to break the chains of local DVI, USB and audio connections. With the Agility system, distance is finally no barrier to high specification, high performance computing. Furthermore, since all signals are now IP, the most elaborate and yet simple-to-use switching and multicast techniques make possible a great variety of uses.

In concert with a suitable Agility receiver unit, the Agility Dual with VNC transmitter supports either two single link DVI video streams or one dual link (very high resolution) DVI video stream. This is in addition to a microphone, speakers and multiple USB peripherals. The distance between them is limited only by the size of your network.

Agility Dual with VNC provides a choice of link connections. Each unit supports both copper-based Gigabit Ethernet cabling as well as Fiber Channel over Ethernet (FCoE). These can be used in parallel to provide up to 2 Gigabit connection speeds with the added benefit of link redundancy that can maintain operation in the event of a failed connection.

Additionally, the Agility Dual with VNC has an in-built VNC server which allows it to stream low-bandwidth versions of its high-resolution output (via a dedicated Ethernet port on the front panel) so that it may be accessed remotely, via a VNC viewer, through any standard network.

2.1 Mixing ServSwitch Agility units

Agility Dual with VNC transmitters are complimentary to the first generation standard Agility models which do not support dual DVI channels or fiber optic linking. It is possible to mix first generation Agility units with Agility Dual and Agility Dual with VNC units on a network. However, whenever the two types are cross connected, the extra abilities of the Agility Dual/Agility Dual with VNC units will be temporarily disabled.

2.2 ServSwitch Agility/Dual/VNC and ServSwitch iPath

Where multiple Agility units are used on a network, we have developed the ServSwitch iPATH server to allow comprehensive and secure central control of all transmitters, receivers and users.

When using an iPATH server to configure Agility units, it is vital that all Agility units that you wish to locate and control are set to their factory default settings. Otherwise they will not be located by the iPATH server. If necessary, perform a [factory reset](#) on each Agility unit.

continued

2.3 One-to-One Configuration

The simplest configuration links one remote unit to a single local unit, either by a direct link or over much greater distances via a high speed network. In both cases, Gigabit cable linking and/or fiber can be used. When both are deployed, connection speeds of up to 2 Gigabits are possible.

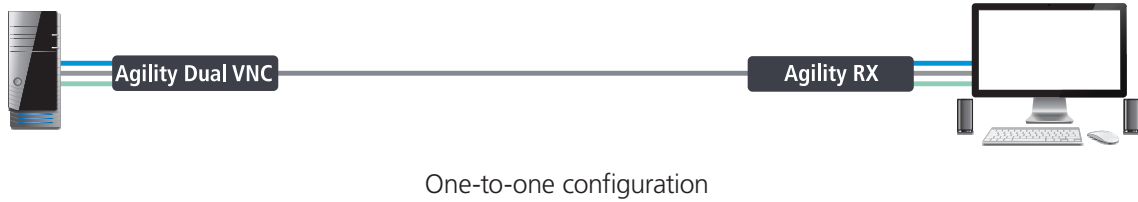

One-to-one configuration

2.4 One-to-Many Configuration

Using multicast techniques, an unlimited number of receivers* can receive video and audio data streams from a single local unit.

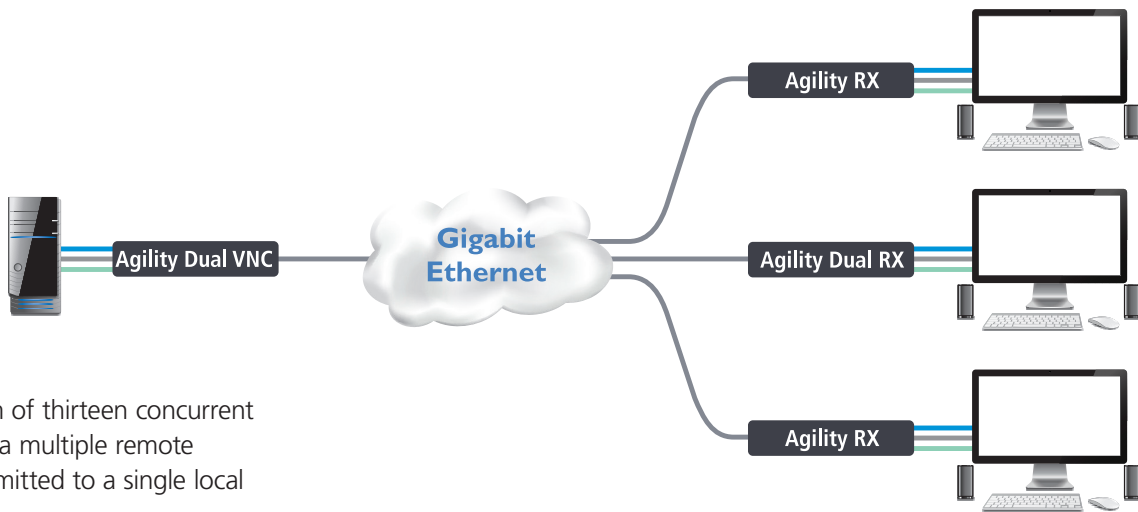

* A maximum of thirteen concurrent USB inputs (via multiple remote units) are permitted to a single local unit.

One-to-many configuration

2.5 Low Bandwidth VNC Connection

Up to sixteen remote users can log in via standard networks to view the output from the Agility Dual with VNC.

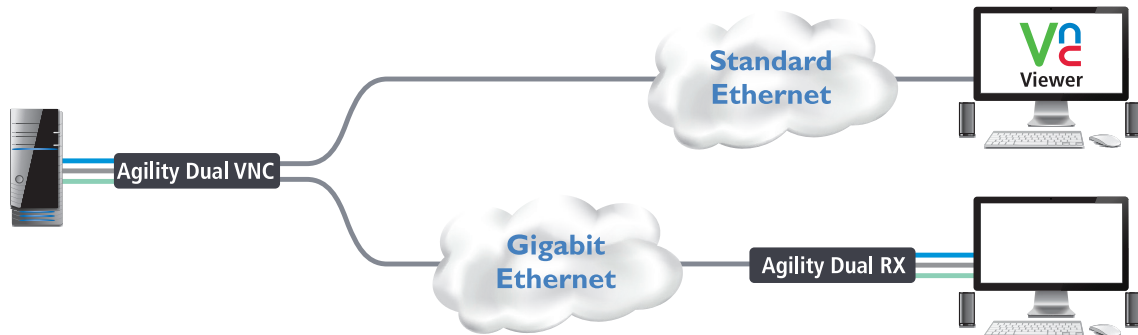

Low bandwidth VNC connection

2.6 ServSwitch Agility features

2.6.1 AFZ lossless codec

The AFZ compression scheme is primarily focused on improving the performance for “natural” images (i.e. photographs and movies) and is automatically selected whenever there is a benefit to do so. The AFZ codec is lossless and is very low latency (a small fraction of a frame delay). It generally achieves 50% improvement (in compression) over the RLE scheme for any areas of the screen that consist of images, gradients, shadows etc., elements commonly found in modern desktop environments.

To maintain compatibility with non AFZ -enabled transmitters and receivers there is an automatic switching method which will revert back to RLE compression when a ServSwitch Agility R1 receiver is connected to the newer Agility R2 series or Agility Dual with VNC.

2.6.2 New feature: AFZ+ codec

AFZ+ compliments the existing AFZ codec by providing greater compression for increased speed where pixel perfect results are not the primary focus. The transmitter video configuration page allows you to choose the required compression mode. Choices are:

- ‘Pixel perfect’ - only uses pixel perfect AFZ,
- ‘Adaptive’ - guarantees frame rate, builds to pixel perfect,
- ‘Smoothest video’ - forces the maximum compression, or
- ‘Advanced’ - allows you to choose the mode:

- ‘AFZ only (pixel perfect),
- ‘AFZ+ Minimum compression’,
- ‘AFZ+ Middle compression’, or
- ‘AFZ+ Maximum compression’.

2.6.3 Magic Eye (anti-dither support added)

The Magic Eye feature increases performance and reduces network traffic when ServSwitch Agility units are used with Apple Macs and other host computers that have dithered video output. It also improves performance if the video source is noisy (e.g. from a VGA-to-DVI converter).

Dithering is a technique used by some graphics cards to improve perceived image quality by continuously varying the color of each pixel slightly. This gives the illusion of more shades of color than the display can really reproduce, and smooths the appearance of gradually shaded areas in images. Unfortunately dithering is an issue for KVM extenders such as ServSwitch Agility because it makes the image appear to be changing all the time even when it is static, thus creating much more network data than can be carried by a Gigabit Ethernet. The result is a reduction in video frame rate, which the user sees as slow mouse response.

Magic Eye works by ignoring small variations in the video from frame to frame. It is enabled by default as it is not obvious to the user that his poor mouse behavior is caused by dithering. In most cases Magic Eye is invisible, but it can produce slight color inaccuracies on the monitor. For full color accuracy, Magic Eye can be disabled (within the transmitter video configuration page) for video sources which are not dithered or noisy.

2.6.4 Transport Layer Security (TLS)

ServSwitch Agility Dual with VNC units support the industry standard Transport Layer Security (TLS) protocol. This offers protection against eavesdropping and tampering by third parties when data are transferred between ServSwitch Agility transmitters and receivers across networks (and also between ServSwitch Agility units and iPath servers).

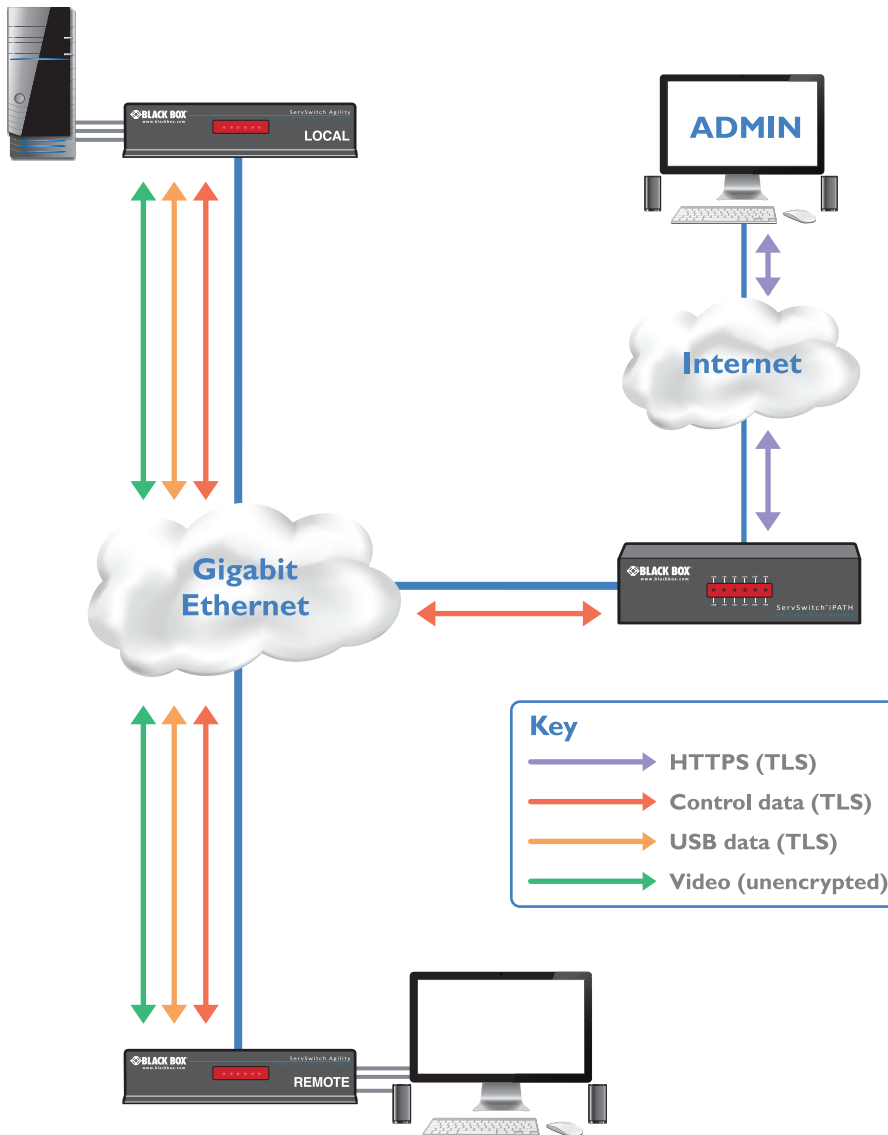

2.7 Teaming operation

The units have dual network interface ports which can be used in parallel to produce important benefits:

- Improved connection speeds up to 2 Gigabits per second, and
- Important link redundancy that can maintain operation in the event of a failed connection.

Teaming offers immediate speed improvements in a one-to-one arrangement...

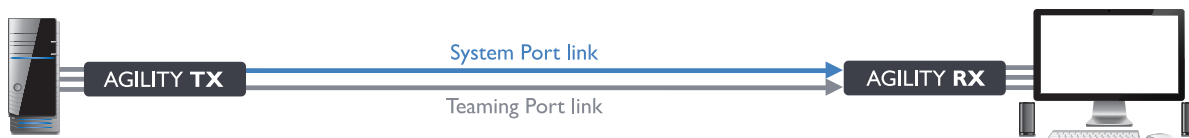

...and also in multicast installations:

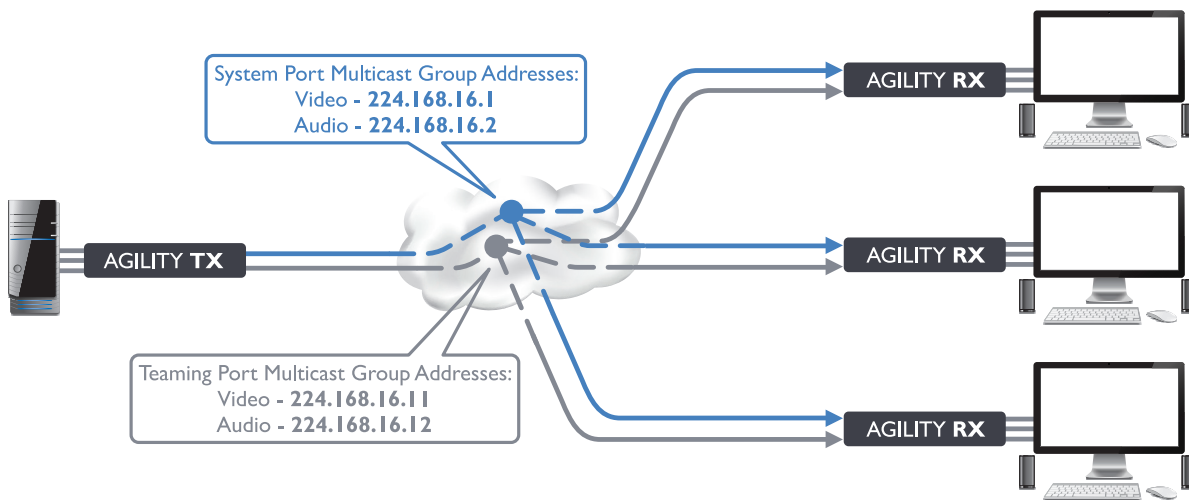

ServSwitch Agility Dual with VNC

2.8 ServSwitch Agility Dual with VNC unit features

The ServSwitch Agility Dual with VNC unit is housed within a durable, metallic enclosure with most connectors situated at the rear panel - the Ethernet and fiber are situated on the front panels.

2.8.1 ServSwitch Agility Dual with VNC local transmitter unit

The smart front faces feature the operation indicators as shown below:

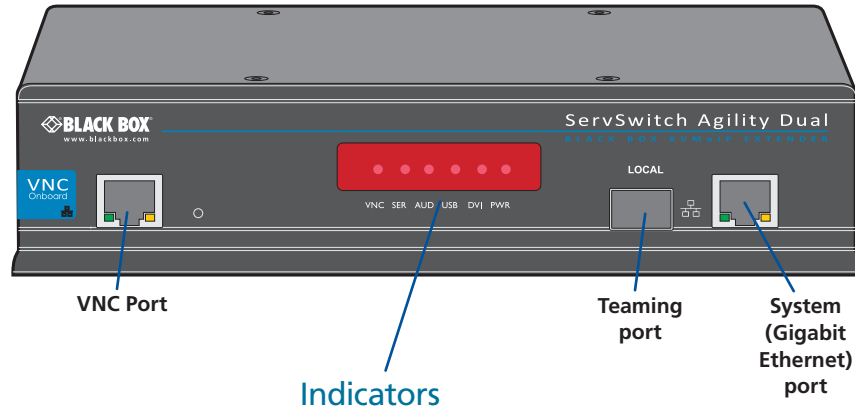

These six indicators clearly show the key aspects of operation:

- VNC On when a valid network is present on either the teaming or system port. Flashes to indicate that a VNC connection is present.
- SER On when the AUX (serial) port is enabled and active.
- AUD On when audio is enabled and active.
- USB On when USB is enabled and active.
- DVI On when either or both DVI video channels are enabled.
- PWR Power indicator.

The rear panel of the local transmitter unit contains most of the connectors:

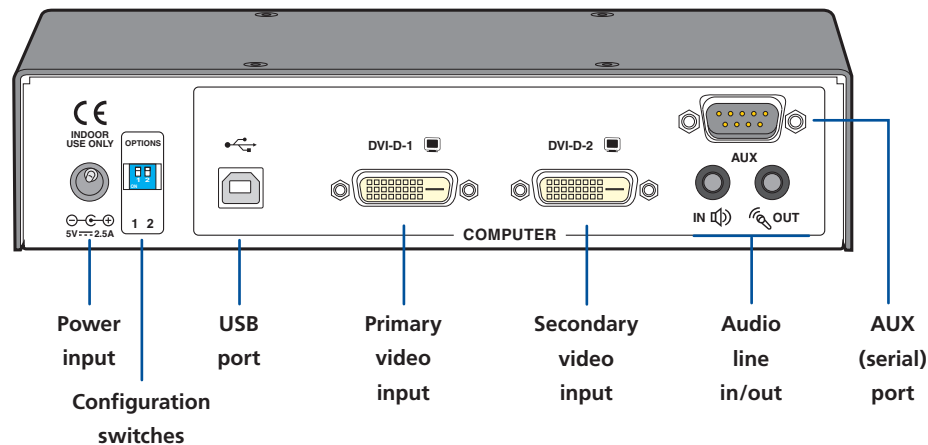

2.9 What's Included

Your package should include the following items. If anything is missing or damaged, contact Black Box at 724-746-5500 or info@blackbox.com.

2.91 ServSwitch Agility Dual with VNC Local Unit Package (ACR1012A-T)

- ServSwitch Agility Dual with VNC local transmitter unit
- Power adapter and power cord
- Information wallet
- Single link DVI-D to DVI-D video cable
- Combined DVI-D and USB cable (6 feet)
- (2) audio cables with 3.5mm stereo jacks (6.5 feet)

2.10 Additional Items You May Need

- Power adapter (P/N: PS650)
- Combined DVI-D and USB cable (type A to B) (P/N: EHN900024U)
- Single link DVI-D to DVI-D video cable (P/N: EVNDVI02)
- USB cable type A to B (6.5 feet) (P/N: USB05)
- 3.5mm Audio cable (6.5 feet) (P/N: EJ110)
- Suitable fiber modules
- Upgrade (serial null modem) cable (6.5 feet) (P/N: EYN257T-XXXX-FF)
- (2) 19" rackmount brackets and (4) screws (P/N: RMK2004 or RMK2004-2)
- VESA mounting bracket and (4) screws (P/N: RMKVESA)

3. Installation

3.1 Mounting

For details about mounting options, please see Appendix G.

3.2 Connections

Installation involves linking the ServSwitch Agility Dual with VNC local transmitter unit to various ports on the host computer, while a ServSwitch Agility or Agility Dual remote receiver unit is attached to your peripherals.

3.2.1 VNC network link

The ServSwitch Agility Dual with VNC contains a VNC server that allows you to transmit a low-bandwidth version of the video output across standard networks to authorized remote viewers.

The VNC link can either be made over the same network as the main System Ethernet port output or via a separate one. In either case, a separate VNC network port is located on the left side of the Agility Dual with VNC front panel for the purpose.

- 1 Connect a CAT 5, 5e, 6, or 7 cable to the VNC socket on the left side of the front panel:

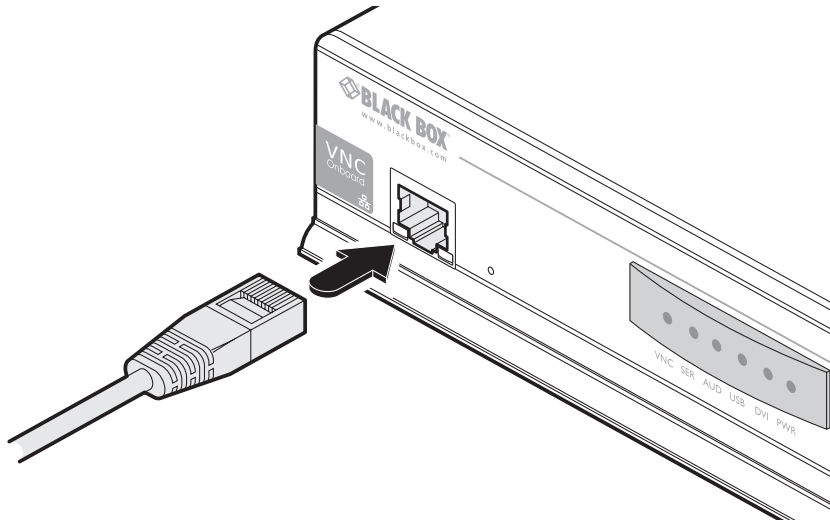

- 2 Connect the other end of the cable to an Ethernet switch.

3.2.2 Local video link(s)

All Agility Dual units can simultaneously support up to two Single Link high resolution video displays at pixel clocks up to 165MHz; or can alternatively support a single Dual Link very high Resolution video display at pixel clocks up to 330MHz (equating to an example display mode of 2560 x 1600 at 60 Hz refresh).

Note: When using one very high resolution DVI-D dual link display, use a DVI-D Dual Link cable to connect the primary video port of the computer system to the DVI-D-1 connector of the ServSwitch Agility Dual with VNC. A dual link cable must also be used at the remote unit.

- 1 Wherever possible, ensure that power is disconnected from the ServSwitch Agility Dual with VNC and the host computer.
- 2 Connect a standard or dual DVI-D link cable to the DVI-D-1 socket on the Local unit rear panel:

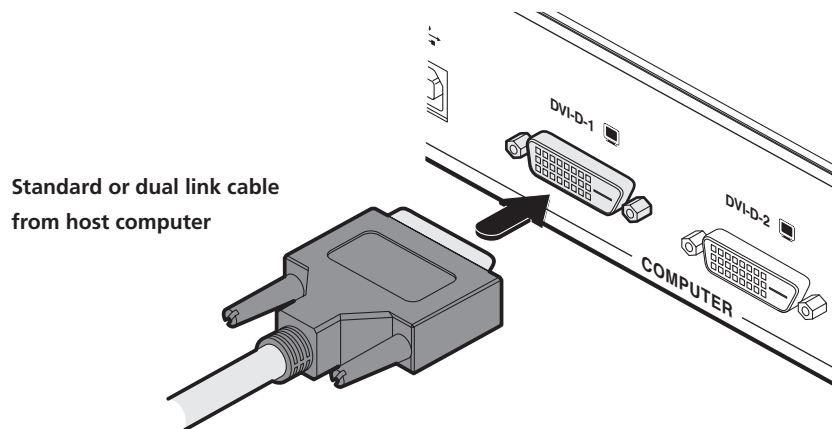

- 3 Connect the plug at the other end of the cable to the corresponding video output socket of the host computer.
- 4 If a secondary DVI-D link is required, repeat steps 2 and 3 for the DVI-D-2 socket:

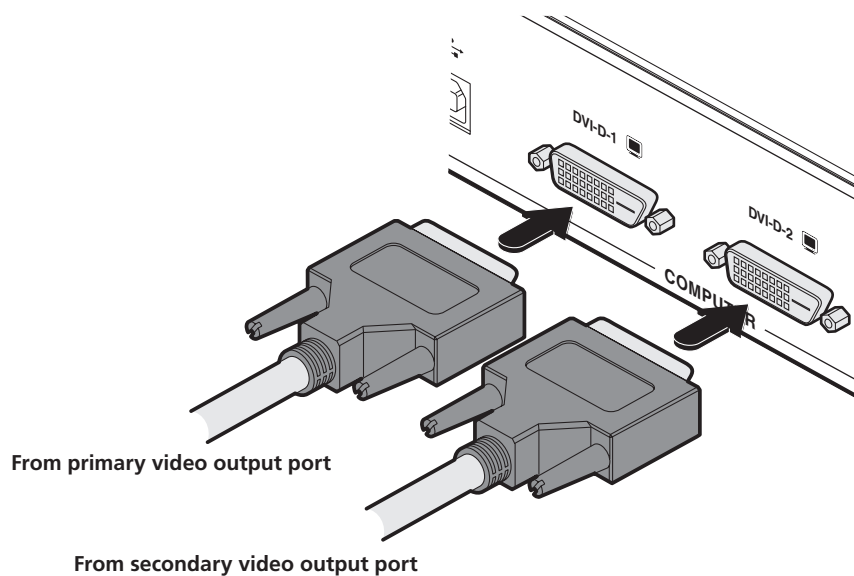

3.2.3 Local Audio Links

All ServSwitch Agility units support two way stereo digital sound so that you can use a microphone as well as speakers.

- 1 Connect an audio link cable between the **IN** socket on the Local unit rear panel and the speaker output (line out) socket of the host computer:

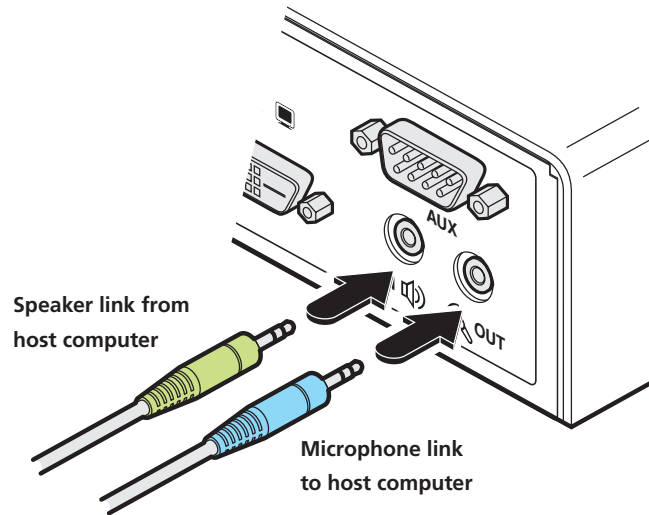

Connect the speaker and microphone cables to audio sockets.

- 2 [Where a microphone is to be used]: Connect a second audio link cable between the **OUT** socket on the Local unit rear panel and the Line In socket of the host computer.

3.2.4 Local USB Link

All ServSwitch Agility units act as USB 2.0 hubs and so can provide four sockets at the Remote unit with only a single connection at the Local unit.

- 1 Connect the type B connector on a USB cable to the USB port on the Local unit rear panel:

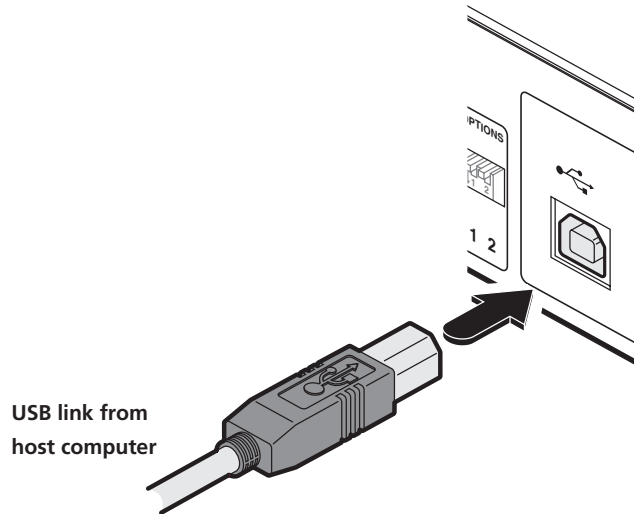

Connect the USB link cable to Local unit socket.

- 2 Connect the type A connector of the cable to a vacant USB socket on the host computer.

3.2.5 Local AUX Port

The AUX port is an RS232 serial port that allows extension of RS232 signals up to a baud rate of 115200. The port has software flow control, but no hardware flow control.

- 1 Ensure that power is removed from the ServSwitch Agility Dual with VNC unit.
- 2 Connect a suitable serial 'null-modem' cable between a vacant serial port on your computer and the AUX port on the right hand side of the ServSwitch Agility Dual with VNC rear panel:

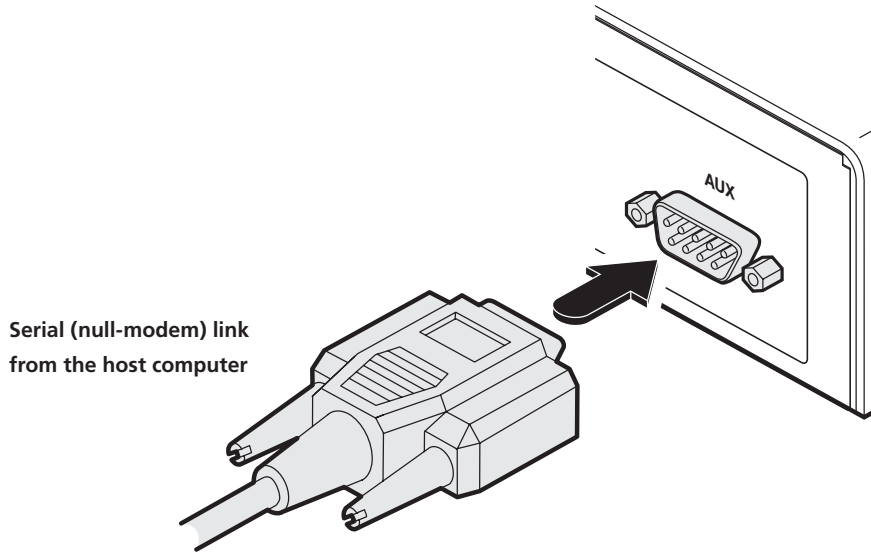

Connecting the serial link cable to Local unit socket.

3.2.6 Local Power In

The ServSwitch Agility Dual with VNC unit is supplied with an appropriate power supply.

- 1 Attach the output lead from the supplied power adapter to the 5V socket on the rear panel of the unit:

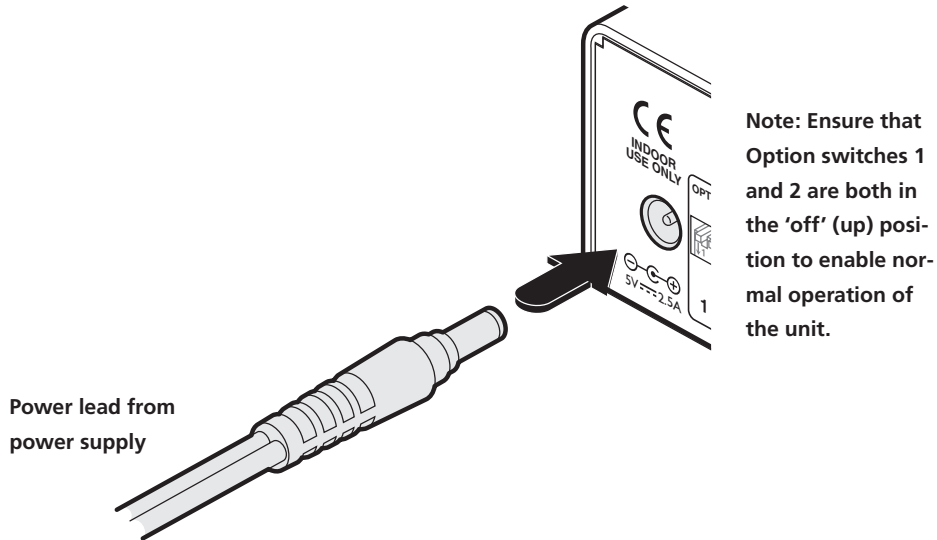

Connect the power supply to the rear panel power socket.

- 2 Connect the IEC connector of the supplied country-specific power lead to the socket of the power adapter.
- 3 Connect the power cord to a nearby power supply socket. When all other connections have been made, switch on the power supply unit.

Note: Both the unit and its power supply generate heat when in operation and will become warm to the touch. Do not enclose them or place them in locations where air cannot circulate to cool the equipment. Do not operate the equipment in ambient temperatures exceeding 104°F (40°C). Do not place the products in contact with equipment whose surface temperature exceeds 104°F (40°C).

3.2.7 High speed links

ServSwitch Agility Dual (and Dual with VNC) units can be either connected directly to each other or via a high speed network. The connections can be copper-based Gigabit Ethernet as well as Fiber Channel over Ethernet (FCoE). These can be used in parallel to provide up to 2 Gigabit connections speeds.

A single System port (Gigabit Ethernet) is provided as standard on the right side of the front panel. Additionally, the Teaming port, located just to the left, allows you to insert either an optional Fiber Channel SFP module or Active Copper SFP module. The chosen module can then allow either a fiber optic or additional Gigabit Ethernet link to be used in parallel with the fixed System (Gigabit Ethernet) port.

3.2.7.1 Using the Teaming port

- 1 Insert an appropriate optional SFP module into the aperture on the front panel:

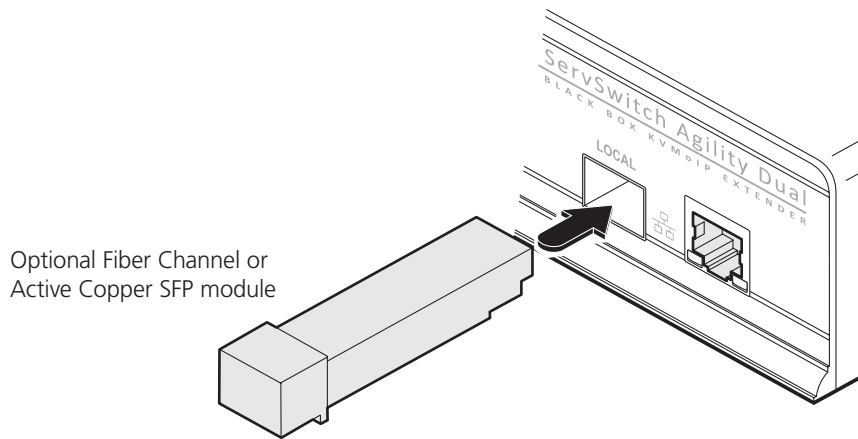

- 2 Make your connection(s) between the chosen SFP module and either the other Agility Dual unit or a suitable network switch:

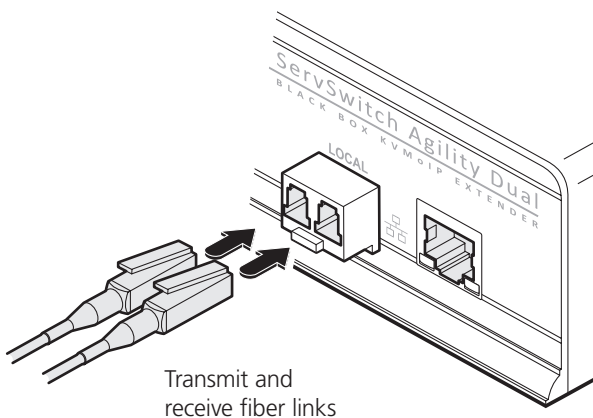

Connect the transmit and receive fiber optic links to the sockets on the Fiber Channel SFP module. Then close the latch over the link connectors to lock them into place.

or

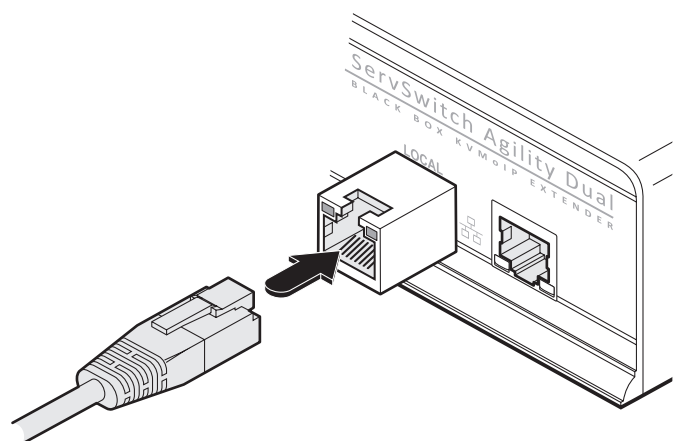

Connect a CAT 5, 5e, 6, or 7 cable to the socket on the Active Copper SFP module.

3.2.7.2 Using the System port

1 Connect a CAT 5, 5e, 6, or 7 cable to the System port socket on the front panel:

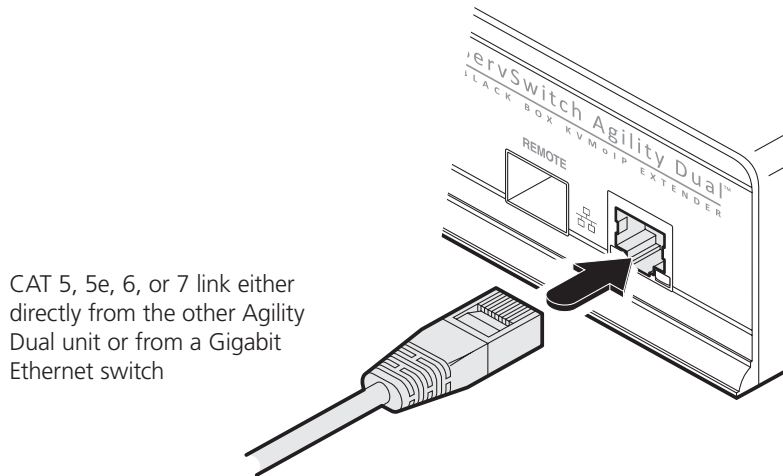

2 Connect the other end of the cable either to the other Agility Dual unit or to a Gigabit Ethernet switch, as appropriate.

3 [For connections via a network] repeat steps 1 and 2 for the other Agility Dual unit.

3.2.7.3 Cable and fiber details

- For direct links over Ethernet cable, the length of cable should not exceed 100 metres (328 feet). Network cables used for connections may be category 5, 5e, 6 or 7 twisted-pair cable. Agility Dual with VNC units have an autosensing capability on their network interfaces, so for direct point-to-point connections, no 'crossover' Ethernet cable is required.
- For direct links via fiber, varying distances can be achieved depending on the module and cable types used. Please refer to the table in Appendix H for detailed information. The fiber links must have crossovers.

4. Configuration

The Agility Dual with VNC unit consists of two distinct sections (as detailed below) which each have their own separate configuration procedure:

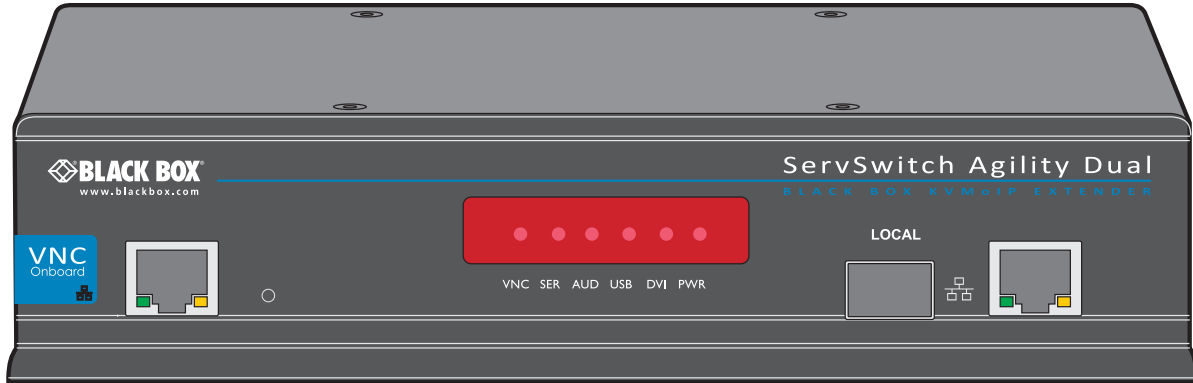

The VNC port

Uses the standard Ethernet port on the left side of the front panel and provides lower-bandwidth image video feeds for use across standard networks and the wider Internet.

[Please see 4.2 The VNC port: Initial configuration for details.](#)

The System and Teaming ports

These use either the Gigabit Ethernet or (optional) Fiber Channel over Ethernet (FCoE) module, on the right side of the front panel and provide high resolution DVI-D image, audio and peripheral feeds.

Please see the opposite page for details >>

4.1 System and Teaming ports: Initial configuration

Agility Dual with VNC units are designed to be as flexible as possible and this principle extends also to their configuration.

4.1.1 Direct linking

Where Agility transmitters and receivers (all models) are directly linked to each other, very little configuration action is required, provided that they have their factory default settings in place. If the standard settings have been changed in a previous installation, you merely need to perform a factory reset on each unit (see below).

4.1.2 Networked linking

Where Agility transmitters and receivers (all models) are connected via networked links, you can either configure them individually, or configure them collectively using an Agility iPath server:

- **Configuring networked Agility units individually** - You need to specify the network addresses of the Agility units so that they can locate each other. This is done by running the [browser-based configuration utility](#) on a computer system linked to the same network as the Agility units.
- **Configuring Agility units collectively** - The Agility iPath server allows you to configure, control and coordinate any number of Agility transmitters and receivers from a single application.

IMPORTANT: When using Agility iPath to configure Agility Dual units, it is vital that all units that you wish to locate and control are set to their factory default settings. Otherwise they will not be located by the iPath server. If necessary, perform a factory reset on each Agility Dual unit (see below).

4.1.3 Manual factory reset

A factory reset returns an Agility transmitter or receiver unit to its default configuration. You can perform factory resets using the [browser-based configuration utility](#) or by using this direct manual method.

4.1.3.1 To perform a manual factory reset

- 1 Remove power from the unit.
- 2 Use a narrow implement (e.g. a straightened-out paper clip) to press-and-hold the recessed reset button on the front panel. With the reset button still pressed, re-apply power to the unit and then release the reset button:

Use a straightened-out paper clip to press the reset button while powering on the unit

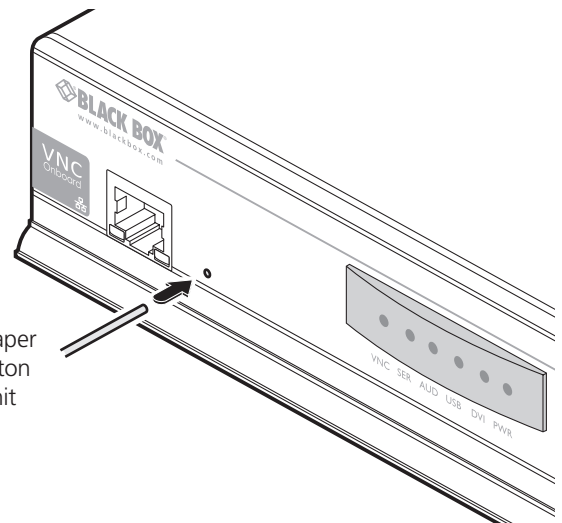

After roughly eight seconds, when the factory reset has completed, five of the front panel indicators will flash for a period of three seconds to indicate a successful reset operation.

4.1.4 Browser-Based Configuration Utility

The browser-based configuration utility within all local transmitter and remote receiver units requires a network connection between a ServSwitch Agility unit and a computer. This configuration utility allows you to perform all of the following functions:

- View/edit the IP network address and netmask,
- Configure separate IP network addresses for video, audio and USB,
- Configure multicast settings (on Remote units),
- Configure video bandwidth settings (on Local units),
- View the current video output (on Local units),
- Perform a firmware upgrade,
- Perform a factory reset.
- Enable/disable and configure the VNC network port settings.

4.1.4.1 Connecting a Computer System for Browser-Based Configuration

- 1 Connect a suitable network cable to the System (Gigabit Ethernet) port on the front panel:

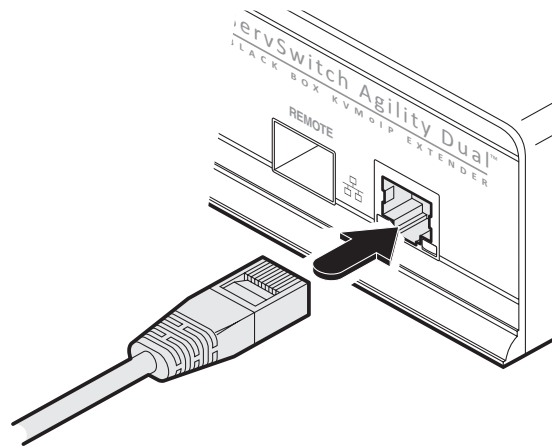

Connect the ServSwitch Agility to a suitable network switch.

- 2 Connect the other end of the link cable to a network switch.
- 3 Similarly, link your computer to the same, or different, switch located on the same network. Note: A Gigabit connection is not essential for configuration purposes.
- 4 If not already switched on, power up your computer and the ServSwitch Agility Dual with VNC unit. You are now ready to use the browser-based configuration utility.

4.1.4.2 Accessing the Browser-Based Configuration Utility

- 1 Temporarily connect the ServSwitch Agility Dual with VNC unit and a computer via a network, as discussed left.
- 2 Run a web browser on your computer and enter the IP address of the ServSwitch Agility Dual with VNC unit, e.g. `http://169.254.1.33`

The default settings are as follows:

	Agility Dual with VNC transmitter	Agility Dual receiver
System port	169.254.1.33	169.254.1.32
Teaming port	169.254.1.43	169.254.1.42

Where the addresses of a unit is not known, perform a manual factory reset (see section 4.1.3) to restore the default addresses.

The opening page of the ServSwitch Agility configuration utility should be displayed and you can now use on-screen help for details of the functions that you wish to perform.

You can find further information about the configuration pages within the [Appendix A](#) later in this guide

4.2 The VNC port: Initial configuration

This section deals with the initial configuration of the VNC port of the Agility Dual with VNC unit. For details about the main System and Teaming ports, please refer to [4.1 System and Teaming ports: Initial configuration](#).

The default IP address of the VNC port is **192.168.1.42**; it is possible to change this either through the VNC viewer or via the [Network configuration page](#).

4.2.1 Initial connection to the VNC port

Configuration of the VNC port section of the Agility Dual with VNC is carried via a network, using a VNC Viewer program running on a computer or mobile device. VNC Viewers are available for most computers, tablets and smartphones.

- If you already have a VNC viewer, please follow the Initial configuration instructions given in section [4.3 Initial configuration](#).

If you do not already have a VNC viewer, there are three options:

- You can download a Windows VNC Viewer from the Agility Dual with VNC itself.
- You can download the latest VNC Viewers for most operating systems via the RealVNC website, or for tablets and smartphones from the appropriate app store.
- Without downloading anything, you can run a Java version of the VNC Viewer inside your web browser.

To download a Windows VNC Viewer from the Agility Dual with VNC unit

Note: The version of VNC supplied within the Agility Dual with VNC supports virtual media.

- 1 Connect the Agility Dual with VNC to an IP network where a suitable computer is available on the same subnet (please see the Installation chapter for connection details).
- 2 On that computer, open an internet browser and enter the default local IP address used by the Agility Dual with VNC:

http://192.168.1.42

The Agility Dual with VNC welcome screen should be displayed:

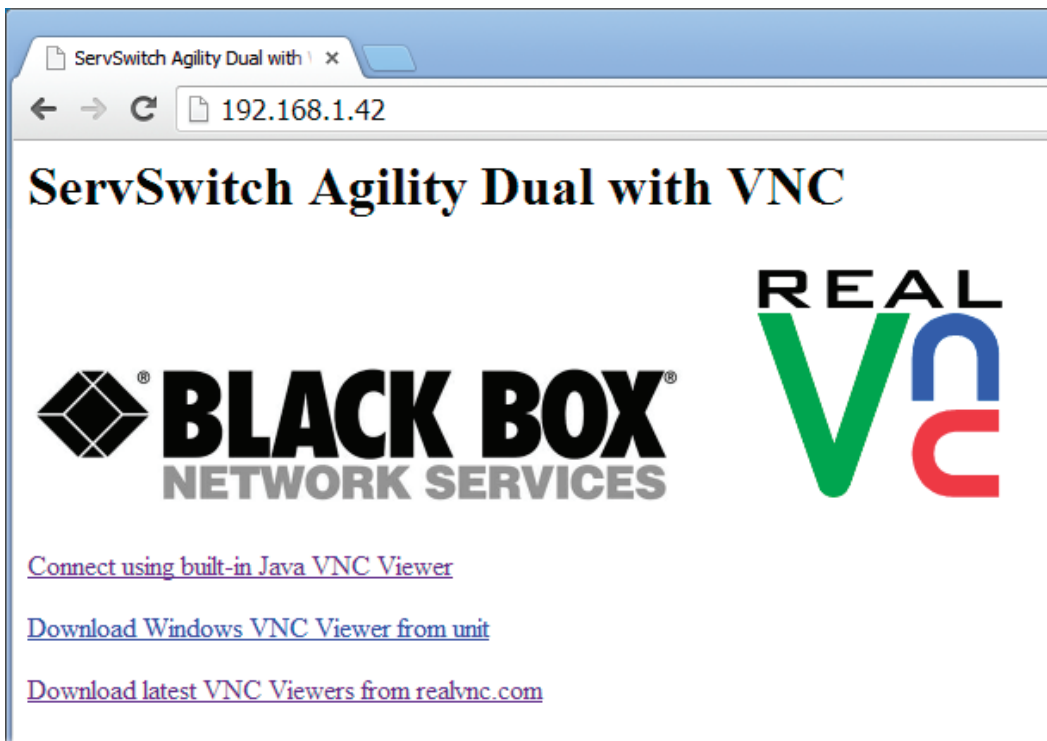

- 3 Click the link 'Download the Windows VNC Viewer from unit'.
- 4 Once the file is downloaded, run it and follow the on screen instructions to open a VNC connection to the Agility Dual with VNC. (The VNC Viewer is a single executable file which does not require an 'installation' step. Simply put the file in a suitable place (such as the Desktop) and run it from there.)

4.2.2 Note on viewers

The windows VNC viewer supplied by the unit is 4.4.3se4. On the Real VNC website you will find later viewers V5. The V5 viewers support a newer 256 bit encryption technique. However, Virtual media functionality is not supported in V5 viewer.

To download a VNC Viewer

To download a (free) VNC Viewer for a desktop or notebook computer, visit the download page of the RealVNC website.

To download a VNC Viewer app for a tablet or smartphone, visit the Apple or Android app store, or look at the RealVNC website for further information.

To use the Java VNC Viewer

- 1 Connect the Agility Dual with VNC to an IP network where a suitable computer is available on the same subnet (please see the Installation chapter for connection details).
- 2 On that computer, open an internet browser and enter the default IP address used by the Agility Dual with VNC:

`http://192.168.1.42`

The Agility Dual with VNC welcome screen should be displayed (as shown on the previous page).

- 3 Click the link Connect using built-in Java VNC Viewer. The Java viewer will load and run inside the browser.

4.3 Initial configuration

To perform the initial configuration, you need to connect the Agility Dual with VNC to an IP network and use a computer located on the same network to connect to it.

To perform the initial configuration

- 1 Connect the Agility Dual with VNC to an IP network (using the **VNC port**) where a suitable computer is available on the same subnet (please see the section [VNC network link](#) for connection details).
- 2 Use a computer connected to the same subnet of the network. On that computer, locate and select the VNC viewer icon ⇨



A connection details dialog will be displayed:

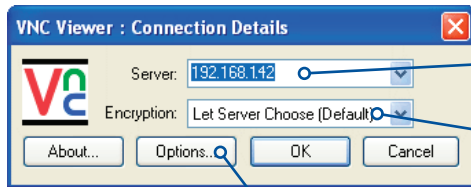

Enter the Agility Dual with VNC address here and click OK

If required, select the encryption mode

Options button

Provides a range of viewer and connection settings

- 3 In the 'Server:' entry, type the address: **192.168.1.42**
- 4 Click the OK button. The viewer window may open straight away (if so continue at step 6) or the system may require user authentication in which case an authentication dialog will be displayed:

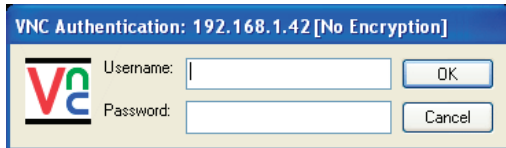

- 5 Enter **admin** as the Username, leave the password entry blank and click the OK button. The viewer window should now open:

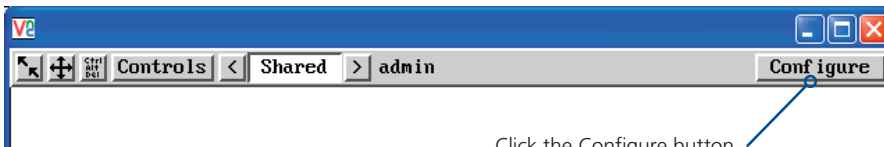

Click the Configure button

6 Click the Configure button to display the Configuration menu:

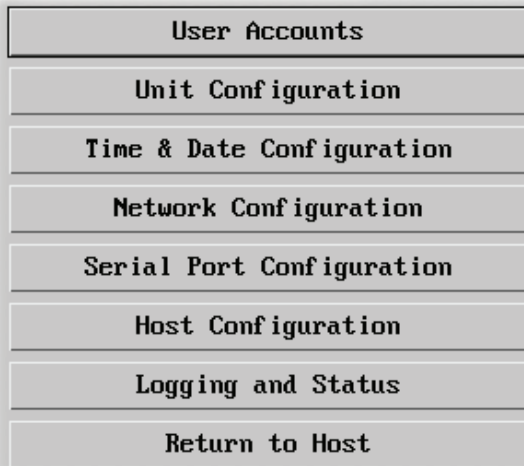

Use the various options (particularly the 'Unit Configuration' and 'Network Configuration' options) to arrange the Agility Dual with VNC to suit your requirements.

See [Appendix A - Configuration menus](#).

Note: To ensure that the Configuration menu is correctly displayed within the VNC viewer, the Agility Dual with VNC must be connected to the video output of its host computer.

4.4 Controls

When clicked, this button reveals a menu of options concerned with keyboard, video and mouse operation.



Single Mouse Mode

This mode is for fast network connections where the cursor response is sufficient to provide instant visual feedback on the remote screen. When enabled, the cursor is 'captured' within the viewer window until you use the 'escape' hot keys.

To quit from single mouse mode, press F8 and then P. Alternatively, enable and use the mouse button escape sequences - see [Advanced unit configuration](#) for details.

The single mouse mode does not require calibration.

Resync Mouse

This option has the same effect as the  button on the menu bar and re-synchronises the local and remote mouse pointers.

Refresh Screen

This option refreshes the whole screen image to remove any artifacts from moved screen items. This is useful when using very low refresh rates on slow speed communication links.

4.5 Mouse Control

This option displays a mouse control dialog and is useful when the remote cursor is failing to respond correctly to your mouse movements, even after using the Resync mouse option.

The mouse control dialog allows you to control the remote mouse cursor using a selection of buttons that you click with your local mouse.

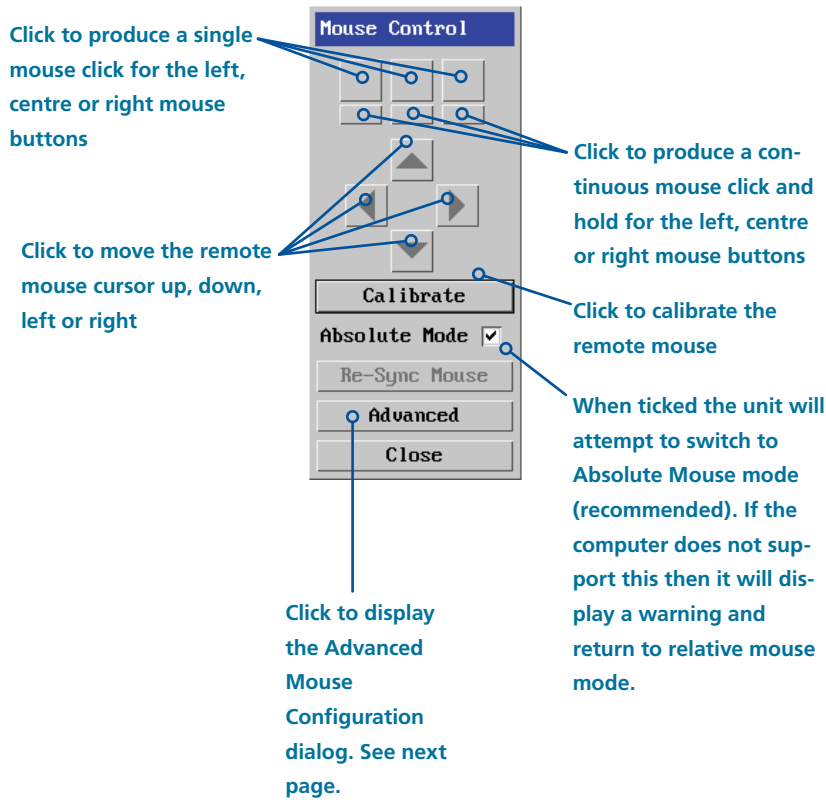

4.6 Advanced mouse configuration

This dialog allows the mouse acceleration to be configured according to the operating system in use and also permits manual fine tuning for situations where problems are encountered with the Calibrate function.

For best results, choose the appropriate *Change motion:* entry to match the host in use.

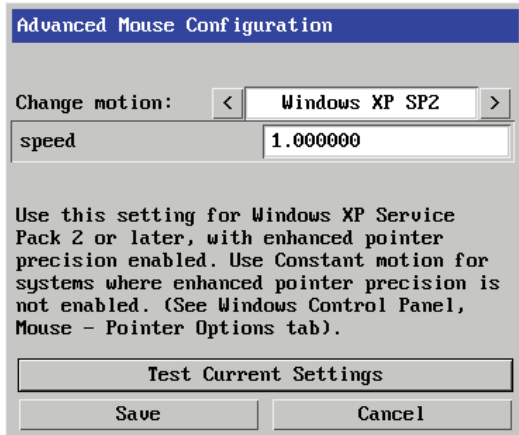

The available Change Motion schemes are: *Constant*, *XFree86*, *Windows Pre-XP*, *Windows XP*, *Windows XP SP2*, *OS/2*, *Solaris*, *Solaris 9* and *Mac OSX*. Most of these offer the Speed setting as the only option, however, the *Windows Pre-Xp* and *XFree86* options contain many other parameters.

When the *Absolute Mode* option is ticked in the main Mouse Control menu, this dialog allows you to adjust the *Absolute Offset* scale:

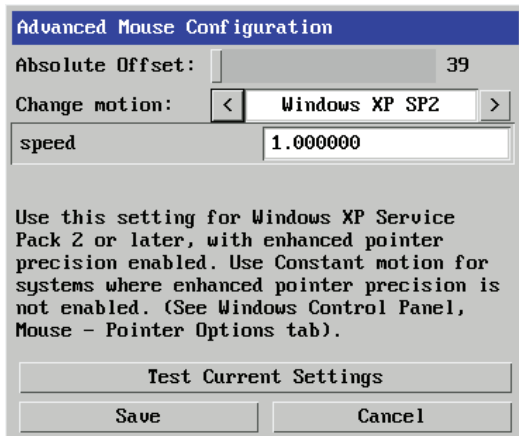

4.7 Info

When selected, this option displays an information dialog showing the current logged on users, the current host, its video mode and its mouse motion details.



4.8 Power switching

When configured (and where you have access rights) this option allows you to control the mains power input to the currently selected host computer.

Note: This option is generally used to power cycle remote systems that have failed to respond. Before switching a system off, ensure that all attempts have first been made to power it down through normal means.

An optional power switch is required to be connected to the AUX port of the Agility Dual with VNC unit in order to control the mains power input into the associated computer. See also [Power switching configuration](#).

To switch a system on or off

- 1 Use the Hosts button to select the required computer.
- 2 Click the Power button and then select the Switch on or Switch off option, as appropriate.

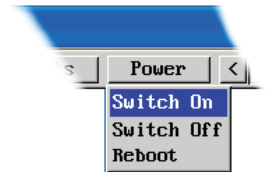

4.9 Keyboard Control

This option displays a keyboard control dialog and is useful for sending keyboard combinations (to the host) that are needed regularly or that are trapped by the Agility Dual with VNC.

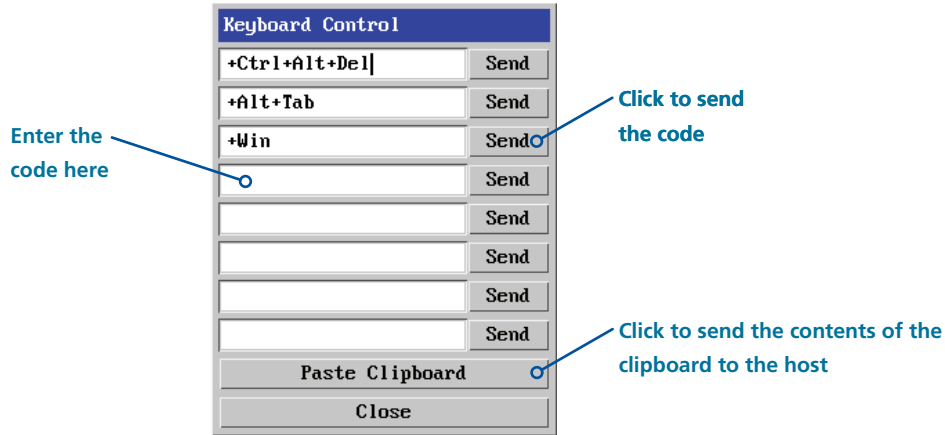

When entering codes:

- + means press down the key that follows
- means release the key that follows
- +– means press down and release the key that follows
- * means wait 250ms (note: if a number immediately follows the asterisk, then the delay will equal the number, in milliseconds)

It is automatically assumed that all keys specified will be released at the end, so there is need to specify -Ctrl or -Alt if these keys are to be released together.

Examples:

'Ctrl + Alt 12' would be expressed as: +Ctrl+ Alt+1–1+2

+N means press the 'N' key

+Scroll means press the Scroll lock key

+Space means press the space key

*Note: If using the Paste Clipboard feature, within the VNC viewer properties, ensure that in the **Inputs** section, the **Share clipboard with server** option is enabled.*

4.10 Video settings

This option provides a range of options related to the video configuration.

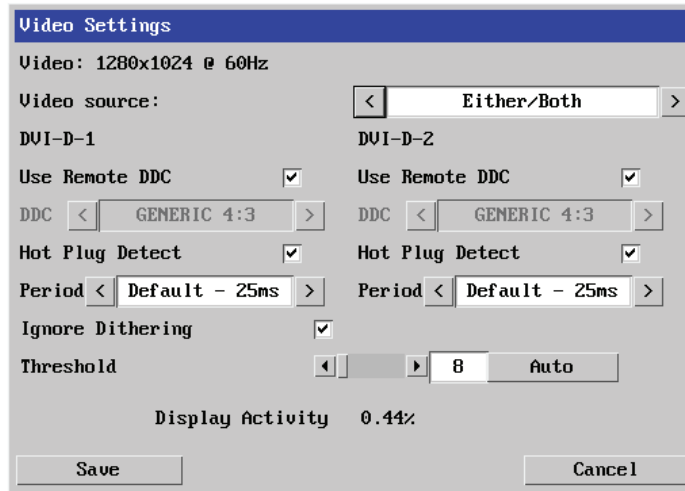

Video source

Selects which video input to use. It is possible to display both single head screens (if connected) or select one over the other. If you are viewing Dual-Link video resolutions, only one head will be available.

Use Remote DDC

Uses the DDC of the monitors connected to the Agility Receiver. If this option is un-ticked you can select a DDC to use that is reported by the Agility Dual with VNC.

Hot Plug Detect

When ticked, allows you to choose one of four hot plug detect periods when, after a display is connected, the DDC information is sought.

Ignore Dithering

Dithering is a technique used by some graphics cards to improve perceived image quality by continuously slightly varying the color of each pixel. This gives the illusion of more shades of color than the display can really reproduce, and smooths the appearance of gradually shaded areas in images. Unfortunately, dithering is an issue for KVM extenders because it makes the image appear to be changing all the time even when it is static. This means that a great deal of unnecessary network data is sent to the VNC viewer, reducing the video frame rate and making mouse response appear slow.

The 'Ignore Dithering' option works by ignoring small variations in the video from frame to frame. This increases performance and reduces network traffic when the host computer is an Apple Mac or another computer that has dithered video output. It also improves performance if the video source is noisy (e.g. from a camera or a VGA-to-DVI converter). 'Ignore Dithering' is disabled by default to give full color accuracy and the best possible frame rate from non-dithered video sources.

Threshold

Adjusts the level of dithering noise that is ignored. The 'Auto' button attempts to choose a suitable value automatically, but the level can also be adjusted manually using the slider or arrow buttons. The best value is of course a compromise between capturing all the 'real' screen changes whilst ignoring the (almost invisible) dithering noise. A good way to choose the value is to watch the Display Activity indicator for a static screen. If the Threshold is too low, the Display Activity will be a high percentage while nothing is really changing. If the Threshold is too high, the Display Activity will be very low (or zero) but some real changes in the screen may be missed.

4.11 Editing the viewer window menu bar

If required, you can customise the menu bar of the viewer window to ensure that it contains only the necessary options.

The menu bar can be edited locally by each user or edited singly by the admin or alternatively, the admin can globally alter the menu bar for all users.

To edit the menu bar locally

1 Login remotely via VNC viewer and display the viewer window.

2 Place the mouse pointer on the menu bar and click the right mouse button. A popup will be displayed:



3 Click on any option within the popup to add it to or remove it from the menu bar.

4 When all changes have been made, click anywhere else within the viewer window.

Changes made in this way will affect the individual user only.

To edit the menu bar via admin

1 Login remotely via VNC viewer as admin user and display the viewer window.

2 Click the *Configure* button in the top right corner of the viewer window.

3 Click the *User Accounts* button.

4 Against the entry for the required user, click the Menu Bar **Edit** button. The following dialog will be displayed:

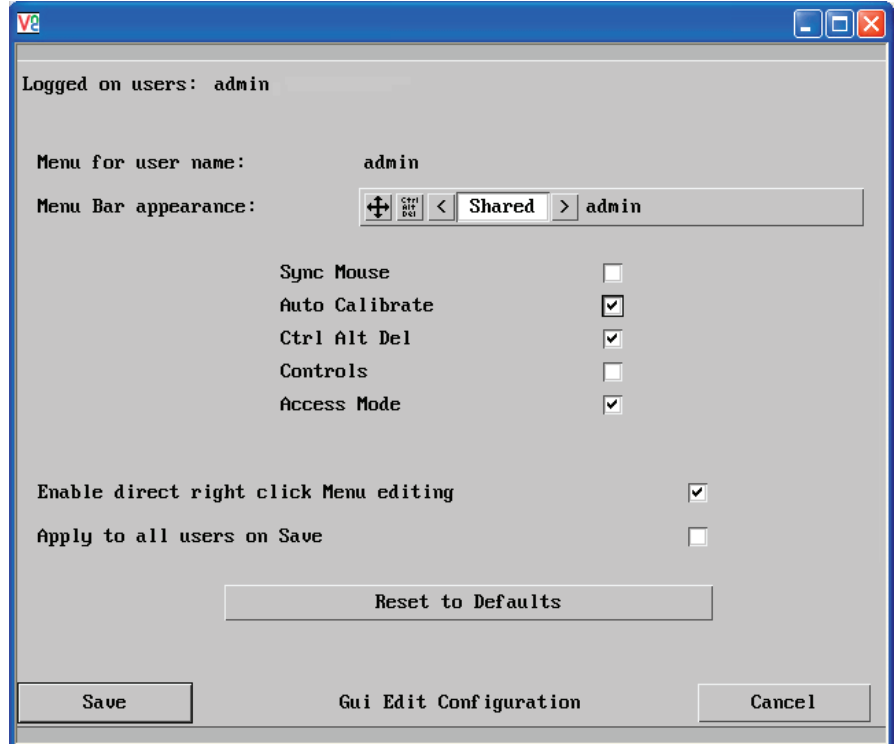

Note: The local menu bar edit popup shown above will only appear if the *Enable direct right click Menu editing* option is ticked within the Gui Edit Configuration screen (for that user) as shown right.

5 Select/deselect the items that you wish to appear on the menu bar. As you do so, the *Menu bar appearance* image will show how the bar will look using your edited settings.

6 Optional: To globally apply your changes, tick the *Apply to all users on Save* option.

7 Click the **Save** button.

4.12 Virtual Media

The Virtual Media feature allows you to remotely make files available to a host computer that is linked to the Agility Dual with VNC. Disk drives, single files or collections of files and folders up to 2GB in size can be mounted via the VNC link, and appear as a read-only disk on the host. This can prove to be an invaluable tool when upgrading host computers from remote positions.

Note: The file transfer is in one direction only, from viewer to host.

Note: Virtual Media does not currently work with Apple Mac systems.

In order to use the Virtual Media feature, the VM link must be made between the Agility Dual with VNC and a USB port on the host computer.

There are two main ways to use Virtual Media:

- Create a read-only 'virtual disk drive' on the host from one or more files chosen at the viewer end. This is useful for copying one or more files from the computer running the VNC viewer to the host computer. See below.
- Export a disk drive (e.g. CD, DVD or USB flash drive) from the viewer computer so it appears as a disk on the host attached to Agility Dual with VNC. A particular use for this is for booting or upgrading the remote host from a CD or other media that you have at the viewer end.

4.12.1 Remotely transferring files to the host as a virtual disk drive

There are several methods of doing this. The easiest method depends on whether:

- The files are already on the clipboard of the viewer computer (following an *Edit -> Copy* operation). See *To remotely transfer files from the clipboard >>*

or

- The files still need to be selected. See *To select and remotely transfer files from the viewer computer >>*

To remotely transfer files from the clipboard

- 1 On the remote system, log into the Agility Dual with VNC using the VNC viewer.
- 2 If not already done, use Windows Explorer to locate and copy the required file(s), or folder(s) to the clipboard.
- 3 Within the VNC viewer window, click the *Controls* button and then select the *Virtual Media* option. A popup similar to the following will be displayed:

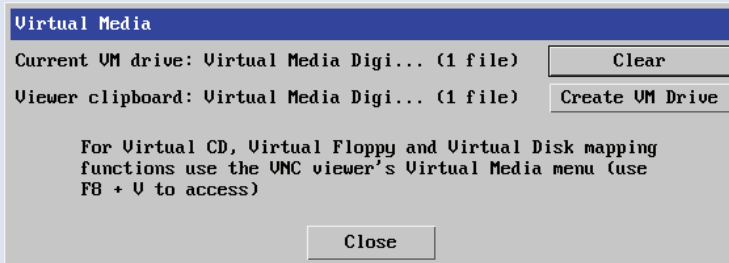

Click the *Create VM Drive* button to announce file availability to the host computer, whereupon a popup will confirm that the new virtual media disk is built.

Note: Remember, at this point the selected files/folders have not yet been transferred to the host system, they are just visible there.

- 4 On the host computer (via the VNC viewer) locate the new virtual drive (shown as a *Removable Disk*) and copy the files to the required location on the host computer.

To select and remotely transfer files from the viewer computer

- 1 On the remote system, log into the Agility Dual with VNC using the VNC viewer.
- 2 Invoke the “Send Files” feature of the VNC viewer (called “File Transfer” in later versions), either by clicking the icon on the viewer’s toolbar or selecting from the F8 menu.
- 3 The viewer will display a window allowing you to select files or a whole folder.

Highlight the required files or folders (up to a maximum of 2GB) that you wish to transfer to the host computer and click the *Open* button. The new disk drive should appear on the host a few seconds later.

Note: The Use Entire Folder button provides a quick way to select a whole folder while you are viewing its contents.

Note: Remember, at this point the selected files/folders have not yet been transferred to the host system, they are just visible there.

- 4 On the host computer (via the VNC viewer) locate the new virtual drive (shown as a *Removable Disk*) and copy the files to the required location on the host computer.

*Note: When using Virtual Media features, within the VNC viewer properties, ensure that in the **Inputs** section, the **Share clipboard with server** and the **Enable file transfer** options are enabled.*

4.12.2 Remotely exporting a disk drive to the host

1 On the remote system, log into the Agility Dual with VNC using the VNC viewer.

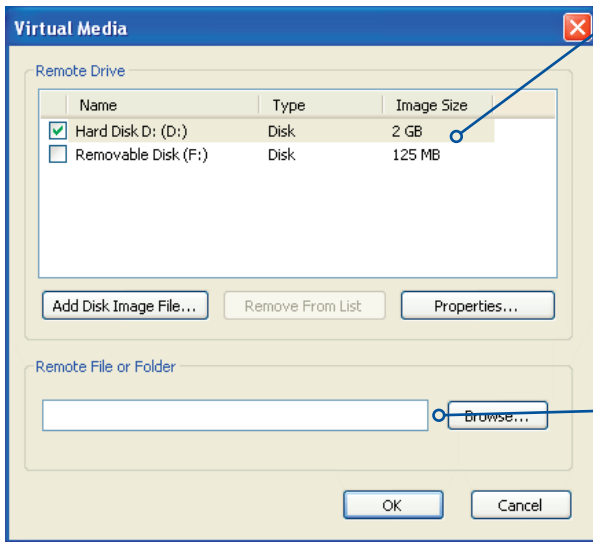

Remote Drive(s)

This section lists any located storage devices on the remote system that are 2GB or less, and which could be copied en masse to the host computer, if desired.

When the **Create ISO Image** option is ticked this creates a bootable disk so that it's possible to boot the host computer from the virtual media drive.

Remote Files or Folders

Click Browse to search for and select single or multiple files/folders to be copied to the host computer.

2 Press **F8** and then **V** to display a *Virtual Media* dialog box:

3 You can select an entire drive or a disk image (e.g. .iso) file:

- Select a disk drive: Click the checkbox adjacent to the listed disk drive that you wish to make available to the host computer, or
- Add a Disk Image File: Select the disk image file and click **Open**.

4 In the *Virtual Media* dialog box, click the OK button to announce the availability of the drive to the host computer. On the host computer, the new drive will appear in the same way as any removable drive would on your computer.

Note: Remember, at this point the selected drive has not yet been transferred to the host system, it is just visible there.

5 On the host computer (either directly or via the VNC viewer) locate the new virtual drive (shown as a Removable Disk) and copy the files to the required location on the host computer.

Note: The Remote File or Folder section of this Virtual Media dialog box provides yet another method of creating a virtual drive from some files or folders, as described above.

4.13 A rough guide to configuring local and remote units

4.13.1 local (transmitter) unit configuration

In an Agility system, the majority of configuration settings are dictated by the remote units. Therefore, the local unit setup (using its browser-based configuration utility) is usually concerned only with three main factors: Its IP address details, the data streams to enable/disable and video signal optimization. Other local unit pages, such as USB Settings, System Messages, Firmware Upgrades and Reboot are generally not used or altered during the majority of installations and are discussed elsewhere in this guide. See Appendix A for explanations of all local configuration page options.

Setting the local address and output signal details

- 1 Display the local unit System Configuration page.
- 2 Ensure that the IP address and netmask for the System port and the Teaming port (if used) are correct. The default settings of 169.254.1.33 and 169.254.1.43 for the two ports respectively are their zero config addresses - these are usually changed to some other address suitable for your installation. Indeed, the zero config address for the System port **MUST** be changed before the Teaming port can be used for network connections.
- 3 Check that the data streams (Enable Video, Enable Audio and Enable USB - plus Enable Serial, if used) are enabled as appropriate. There are similar options within the remote unit configuration and it is important that the settings in both units are the same. If an option is ticked in one unit but unticked in the other, then that data stream will remain disabled. If you make a change, remember to click the Update Now button.

Optimizing the local video signal

Note: Where the Agility system is linked via two Gigabit links with sufficient available bandwidth, there should be no need to alter the default settings on this page.

- 1 Display the local unit System Configuration page and then change to the Video Configuration page.
- 2 Make changes to the controls as necessary for each video port. There is no single combination of adjustments that will suit all installations, but generally:
 - If moving video images are being shown frequently, then leave Frame Skipping at a low percentage and instead reduce the Peak Bandwidth Limiter and Color Depth.
 - Where screens are quite static, try increasing the Background Refresh interval and/or increasing the Frame skipping percentage setting.

Make changes one at a time, in small steps, and view typical video images so that you can attribute positive or negative results to the appropriate control.

See Video Configuration for individual explanations of the controls.

- 3 Click Update Now to apply each setting change.

4.13.2 Remote (receiver) unit configuration

In an Agility system, it is the remote unit (receiver) that determines where and how data signals are sent (and received) by the local unit. Although numerous topologies (one-to-one, one-to-many, many-to-one, etc.) are made possible by the Agility system, they are all dependent on two underlying modes of operation: either Unicast or Multicast transmission. Where multicast transmission is not invoked for video and/or audio data, operation will be automatically served by unicast network transmission technologies.

The remote unit setup (using the System Configuration page of its browser-based configuration utility) is concerned with four main factors: Its own IP address(es), the data streams to enable/disable, the IP address(es) of the local unit and multicast transmission details. Other pages, such as USB Settings, System Messages, Firmware Upgrades and Reboot are generally not used or altered during the majority of installations. For further details about remote unit configuration pages, please see the Agility and Agility Dual guide.

Configuring the remote unit

- 1 Display the remote unit System Configuration page.
- 2 In the System Configuration section, ensure that the IP address and Netmask settings for the System and Teaming ports for this remote unit are correct. The default settings of 169.254.1.32 and 169.254.1.42 for the two ports respectively are their zero config addresses - these are usually changed to some other address suitable for your installation. Indeed, the zero config address for the System port **MUST** be changed before the Teaming port can be used. Enter the new values and click the Update Now button. The System IP Address that is set here will be sent to the local unit as the destination for transmitted data (when operating in unicast mode). The Gateway entry is only necessary when the local unit is located on a separate network to the remote unit.
- 3 Check that the data streams (Enable Video, Enable Audio and Enable USB - plus Enable Serial, if used) are enabled (ticked) or disabled (unticked) as appropriate. There are similar options within the local unit configuration; If one of these options is ticked in one unit but unticked in the other, then that data stream will remain disabled. If you make a change, click the Update Now button.
- 4 If necessary, alter the Audio Input Type to match your audio input. The line option is for a stereo line input, mic and mic boost are for mono microphones, the latter benefiting from a +20dB gain boost.
- 5 In the Target Transmitter Unit Settings section, you need to enter the System port and Teaming port IP addresses for the local unit that will be supplying the video, audio, USB and serial data streams. This section allows you to determine which peripherals should use the second link. Most often all streams are supplied by the same local unit, so common System and Teaming port addresses can be applied to all streams. However, it is possible to receive them from different locations, in which case, click the blue arrow to reveal the separate video, audio, USB and serial addresses. For all five peripherals, the System port of the targeted local unit is always used to carry the respective data streams; your choices involve which of those five should also use the secondary Teaming port link to spread the load(s). For each peripheral, the first IP address is that of the targeted local unit's System port. IP Address 2 corresponds to the Teaming port and is used only when the checkbox above is ticked. The default settings for all entries are the standard IP addresses that are factory set within every local unit (169.254.1.33 and 169.254.1.43). Change these to the appropriate addresses on your transmitter(s) and click the Update Now button to save and activate them.

continued

6 For installations that will include more than one remote unit, for either video or audio or both, then you need to configure the Multicast Settings section.

The two Video and the single Audio Multicast sub-sections are configured in exactly the same way:

- First, tick the Enable Multicast Video / Enable Multicast Audio check box.
- Next, enter appropriate Multicast Addresses for the System port Video/Audio data stream(s). The set of IP addresses between 224.0.0.0 and 239.255.255.255 are specifically reserved for multicast operations. Within a private enterprise network, you merely need to choose a location that is currently unused. However, if your link will pass through public networks, then attention must be given to finding an address within these limits that is not already reserved for special use. The IANA (Internet Assigned Numbers Authority) website: iana.org provides a list of publicly reserved addresses.
- Next, enter appropriate Multicast Address 2 entries for the Teaming port Video/Audio data stream(s).

The video and audio multicast addresses must be different, as must the System and Teaming ports. The addresses that you enter will be used by the remote unit to 'listen-in' on the video and audio data streams output by the local unit. The same IP addresses need to be set on every remote unit that will similarly receive the video and audio data streams.

7 Click the Update Now button to save.

Repeat the IP addressing and multicast configuration steps for all remote units that will be part of the one-to-many installation.

For most installations, the successful implementation of these configuration steps will result in a correctly working system.

4.14 Performing an upgrade

Agility Dual with VNC units are flash upgradeable using the method outlined here. However, for larger installations we recommend that you use the ServSwitch iPath manager to upgrade multiple Agility Dual units. When using the method below, the Agility dual unit will be upgraded in sequence.

IMPORTANT: Upgrades must be performed on both the local and the remote units at the same time. Mixed firmware operation is not supported.

WARNING: During the upgrade process, ensure that power is not interrupted as this may leave the unit in an inoperable state.

If the upgrade process is interrupted and fails, it may be necessary to switch to the backup firmware image in order to regain operation. See next page for details.

4.14.1 To upgrade a single unit via network link

1 Download the latest upgrade file from Black Box technical support.

Note: There are separate upgrade files for local and remote units.

2 Temporarily connect the Agility Dual with VNC unit and a computer via a network (see [browser-based configuration utility](#) section for details).

3 Run a web browser on your computer and enter the IP address of the Agility Dual with VNC unit to be upgraded.

4 Click the Firmware Upgrade link. Within the Firmware Upgrade page, click the Choose File button. In the subsequent file dialog, locate the downloaded upgrade file - check that the file is correct for the unit being upgraded.

5 Click the Upgrade Now button. A progress bar will be displayed (however, if your screen is connected to the unit being upgraded then video may be interrupted) and the indicators on the front panel will flash while the upgrade is in progress.

6 The indicators should stop flashing in less than one minute, after which the unit will automatically reboot itself. The upgrade process is complete.

Note: It is possible to downgrade the Agility firmware. After installing the older firmware, perform a factory reset on each Agility in order to clear the configuration file.

Note: If you have an Agility unit at v3.3 or higher, and you wish to downgrade its firmware via iPATH v2.5 to v2.9 (so as to use it within an iPATH v2.5 system), this can only be done via the copper interface and not the fiber interface.

4.15 Options switches

A pair of Options switches are located on the rear panel of every Agility Dual with VNC unit.

4.15.1 Switch 1 - firmware image select

Each Agility Dual with VNC unit retains a backup firmware image which can be used in situations where the primary firmware becomes corrupted (most often through failed upgrade operations). Using the backup firmware will allow you to regain operation of the unit.

- | | | |
|------------------------|-----|--|
| Option switch 1 | OFF | Normal operation using the main firmware |
| | ON | Operate using the backup firmware image |

Option switch 2 is reserved and must remain in the OFF (up) position for normal operation.

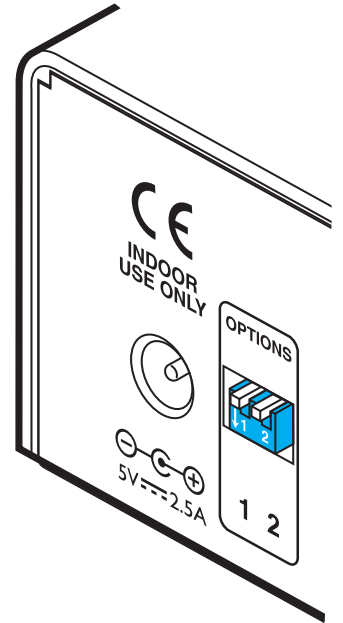

5. Operation

In operation, many ServSwitch Agility installations require no intervention once configured. The local transmitter and remote receiver units take care of all connection control behind the scenes so that you can continue to work unhindered.

5.1 Front Panel Indicators

The six front panel indicators on the ServSwitch Agility Dual with VNC unit provide a useful guide to operation.

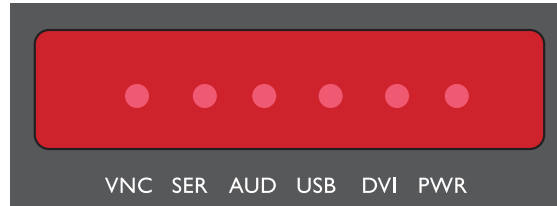

These six indicators clearly show the key aspects of operation:

- VNC On when a valid network is present on either the teaming or system port.
Flashes to indicate that a VNC connection is present.
- SER On when the AUX (serial) port is enabled and active.
- AUD On when audio is enabled and active.
- USB On when USB is enabled and active.
- DVI On when either or both DVI video channels are enabled.
- PWR Power indicator.

5.2 Using the VNC viewer

1 On a network connected computer, locate and select the VNC viewer icon ⇨



A connection details dialog will be displayed:

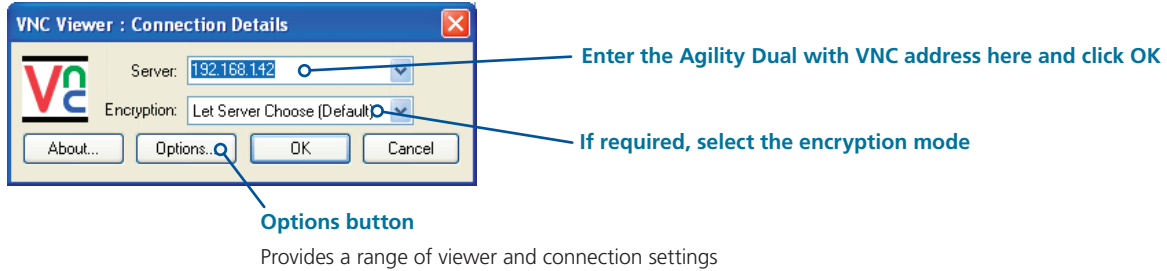

- 2 In the 'Server:' entry, type the network address that has been configured for the VNC port of the Agility Dual with VNC unit.
- 3 Click the OK button. The viewer window may open straight away or the system may require user authentication, in which case an authentication dialog will be displayed:

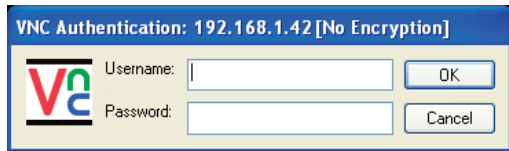

4 Enter your Username and Password and click the OK button. The viewer window should now open ⇨

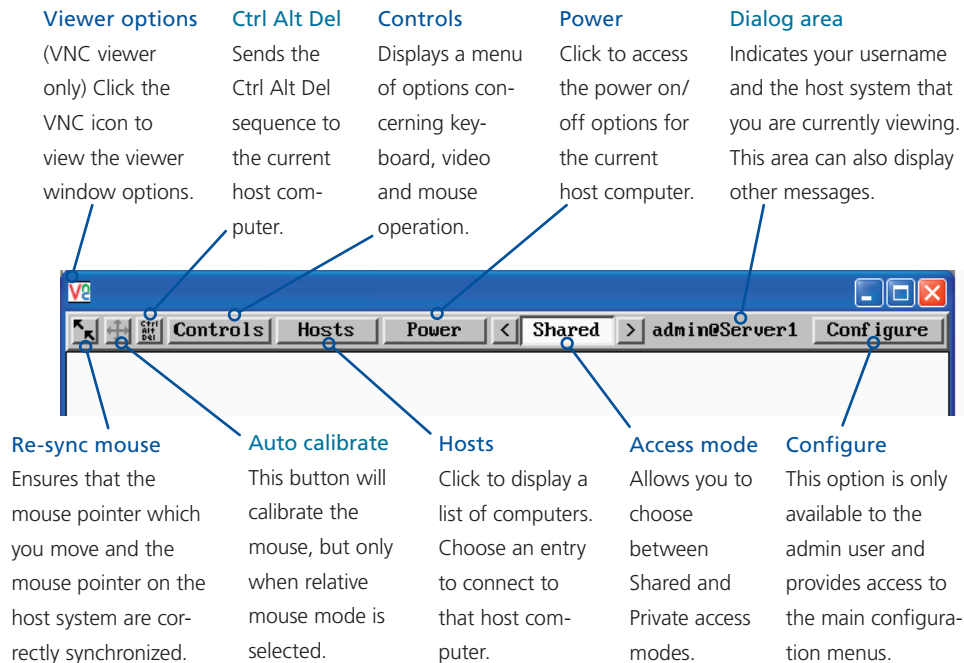

5.2.1 When using the viewer window

What is the best screen resolution to use?

The best resolution for your computer is one that is larger than the screen of the host computer that you are viewing. This will allow you to see everything without scrolling around. Alternatively, the VNC viewer can be set to scale the image to fit your screen, but remember that some pixel dithering effect will be seen when scaling is used.

How do I navigate around a larger screen?

If the screen that you are viewing has a larger resolution than your viewing window you will need to scroll around to see all items. The viewer window allows you to 'bump scroll' (only in full screen mode). This means that when your mouse cursor bumps against the edge of the screen, the screen image will scroll across automatically.

How do I escape from full screen mode?

Press the F8 button. This button is changeable but is most often set to F8.

How do I make the most of a slow connection?

The VNC viewer is slightly better suited to slower connections than the browser viewer because it offers more options. Click the Options button of the VNC viewer when entering the Agility Dual with VNC address during log on.

Rate limit mouse events

When selected, this mode greatly reduces the mouse movement data that are sent to the host computer. When you move the local mouse, the remote cursor will catch up roughly once per second.

6. Further information

This chapter contains a variety of information, including the following:

- [Appendix A. Configuration menus \(via VNC\) - see opposite](#)
- [Appendix B. VNC viewer window options](#)
- [Appendix C. The KVMADMIN utility](#)
- [Appendix D. Java viewer options](#)
- [Appendix E. Hotkey sequences](#)
- [Appendix F. Known working video modes](#)
- [Appendix G. Mounting options](#)
- [Appendix H. Fiber modules and cables](#)
- [Appendix I. Safety Information](#)

Appendix A. Configuration menus (via VNC)

When viewing remotely via VNC, the unit has a main configuration menu through which you can access various sub menus to configure particular items.

To view the main configuration menu

- 1 Using VNC viewer or a browser, log on as the 'admin' user.
- 2 Click the 'Configure' button in the top right corner. The main configuration menu will be displayed:

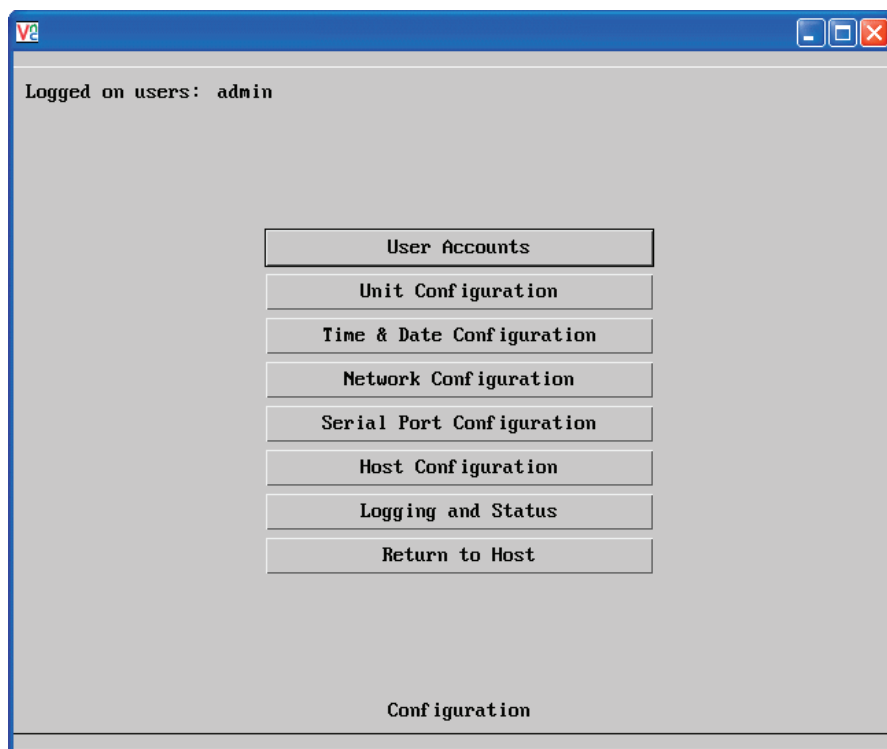

The various configuration pages are covered within this appendix:

- [User accounts](#)
 - [Gui edit configuration](#)
- [Unit configuration](#)
 - [Advanced unit configuration](#)
- [Time & date configuration](#)
- [Network configuration](#)
- [Serial port configuration](#)
- [Host configuration](#)
 - [Power switching configuration](#)
- [Logging and status](#)

User accounts

Up to 16 users can be created by the admin user, each with their password. One of the 16 users can be the admin user. This user has access to the units configuration menu. Ticking the 'IsAdmin' box creates the Admin user. The admin user can also determine whether the users are allowed access to the power control menu in order to turn servers on and off.

User Name	Password	Remote	Power	IsAdmin	Menu Bar
admin	Enter Password	<input checked="" type="checkbox"/>	<input checked="" type="checkbox"/>	<input checked="" type="checkbox"/>	Edit
	Enter Password	<input type="checkbox"/>	<input type="checkbox"/>	<input type="checkbox"/>	Edit
	Enter Password	<input type="checkbox"/>	<input type="checkbox"/>	<input type="checkbox"/>	Edit
	Enter Password	<input type="checkbox"/>	<input type="checkbox"/>	<input type="checkbox"/>	Edit
	Enter Password	<input type="checkbox"/>	<input type="checkbox"/>	<input type="checkbox"/>	Edit
	Enter Password	<input type="checkbox"/>	<input type="checkbox"/>	<input type="checkbox"/>	Edit
	Enter Password	<input type="checkbox"/>	<input type="checkbox"/>	<input type="checkbox"/>	Edit
	Enter Password	<input type="checkbox"/>	<input type="checkbox"/>	<input type="checkbox"/>	Edit
	Enter Password	<input type="checkbox"/>	<input type="checkbox"/>	<input type="checkbox"/>	Edit
	Enter Password	<input type="checkbox"/>	<input type="checkbox"/>	<input type="checkbox"/>	Edit
	Enter Password	<input type="checkbox"/>	<input type="checkbox"/>	<input type="checkbox"/>	Edit
	Enter Password	<input type="checkbox"/>	<input type="checkbox"/>	<input type="checkbox"/>	Edit
	Enter Password	<input type="checkbox"/>	<input type="checkbox"/>	<input type="checkbox"/>	Edit
	Enter Password	<input type="checkbox"/>	<input type="checkbox"/>	<input type="checkbox"/>	Edit
	Enter Password	<input type="checkbox"/>	<input type="checkbox"/>	<input type="checkbox"/>	Edit
	Enter Password	<input type="checkbox"/>	<input type="checkbox"/>	<input type="checkbox"/>	Edit
	Enter Password	<input type="checkbox"/>	<input type="checkbox"/>	<input type="checkbox"/>	Edit

Enable Password Hashing

Save User Configuration Cancel

User Name

All user names must consist of lower case characters or numbers only. No symbols or upper case characters are permissible. The user name can be between 1 and 32 characters in length but cannot contain foreign characters.

Password

Each password can be between 1 and 16 characters in length. A suitable password is best constructed using a mixture of more than 6 letters, numbers and punctuation characters.

Local

This column is greyed out as this feature is not available on Agility Dual with VNC.

Remote

When ticked, the selected user can gain access via an IP network link (such as a local intranet or the wider Internet, depending on how the Agility Dual with VNC is connected) and/or Console Server access.

Power

When ticked, the selected user will be permitted to control the power input to host systems (requires optional power control switch unit(s) to be fitted).

Menu Bar

Optionally click to customise the menu bar for each user. See next page.

Enable Password Hashing

This enables the storing of passwords in an encrypted format, which provides added security.

Gui edit configuration

If required, you can customize the menu bar of the viewer window to ensure that it contains only the necessary options.

The menu bar can be edited locally by each user or edited singly by the admin or alternatively, the admin can globally alter the menu bar for all users.

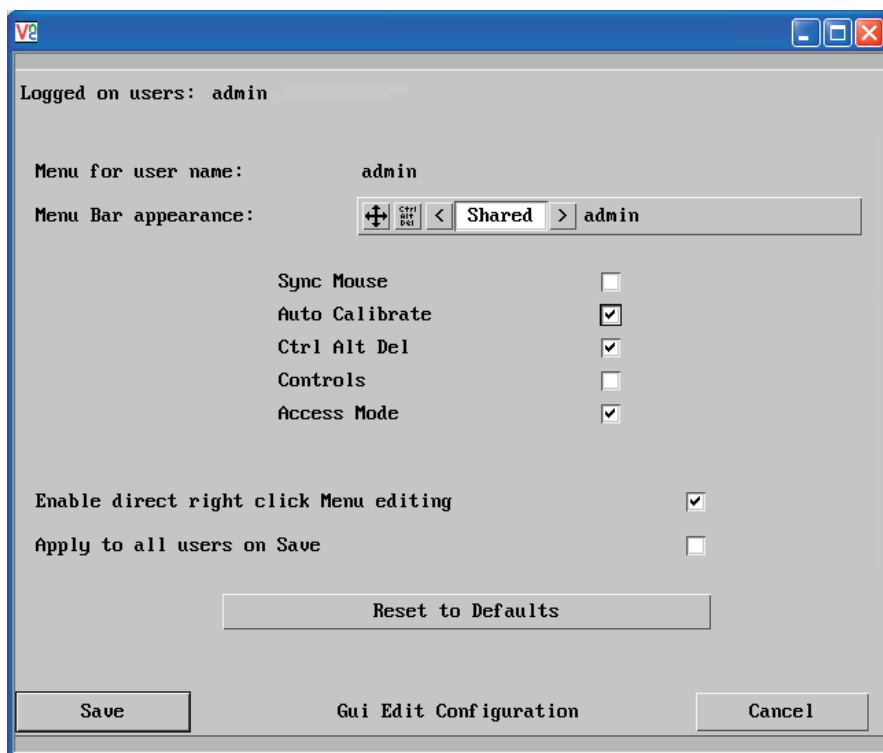

To edit the menu bar locally

- 1 Login remotely via VNC viewer and display the viewer window.
- 2 Place the mouse pointer on the menu bar and click the right mouse button. A popup will be displayed:



- 3 Click on any option within the popup to add it to or remove it from the menu bar.
 - 4 When all changes have been made, click anywhere else within the viewer window.
- Changes made in this way will affect the individual user only.

Unit configuration

This page provides access to a selection of both basic and advanced settings for the Agility Dual with VNC. Many of the settings displayed here are also accessible through the on-screen menu.

Logged on users: admin

Hardware Version:	ACR1012A-T
Firmware Version:	4.0
Host Keyboard Layout	< UK >
Admin Password	Enter Password
Unit Name	
New Connections Private	<input type="checkbox"/>
Menu Bar Toggle Hot Key	< F12 >
Display Menu Bar for New Connections	<input checked="" type="checkbox"/>
Encryption	< Prefer Off >
Number of simultaneous UNC Users	4
UNC Viewer Hot Key Sequence	< Ctrl+Alt >

Advanced Unit Configuration

Save Unit Configuration Cancel

Hardware Version

Indicates the version of the electronic circuitry within the Agility Dual with VNC unit.

Firmware Version

Indicates the version of the internal software within the Agility Dual with VNC flash memory. This may be updated using the flash upgrade procedure.

Host Keyboard Layout

Use the arrow buttons to match the keyboard layout expected by the host system.

Admin (Change) Password

Click this button to enter/edit the password that will be used to gain administrator access to the Agility Dual with VNC.

Unit Name

The name entered here will be displayed on the local menus and the remote VNC viewer/browser windows.

New Connections Private

Allows you to determine whether new local or VNC connections should be set up as private (when ticked) or as shared (when unticked).

Menu Bar Toggle Hot Key

Determines the function key that can be used to display/hide the menu bar within the VNC screen.

Encryption

Four options are available: Always On, Prefer Off, Prefer On, or Maximum. The one to choose depends on the specific details of your installation. The use of encryption imposes a slight performance overhead of roughly 10% but is highly secure against third party intrusion. Maximum selects 256 bit encryption.

Number of simultaneous VNC Users

Allows you to restrict the number of concurrent VNC sessions. The maximum number is 16 and the default is 4.

VNC Viewer Hot Key Sequence

When using the VNC Viewer, you can use key press combinations to select host computers and also to display the host selection menu. This option allows you to choose which keys should be used to form the hotkeys that will precede a switching command. The default setting is CTRL + ALT, so as an example when you press the CTRL ALT and 2 keys, the viewer will change to the host with "Hotkey Host Number" 2 - see [Host configuration](#).

[Advanced Unit Configuration](#)

Advanced unit configuration

Click this button to display advanced options that do not normally require alteration.

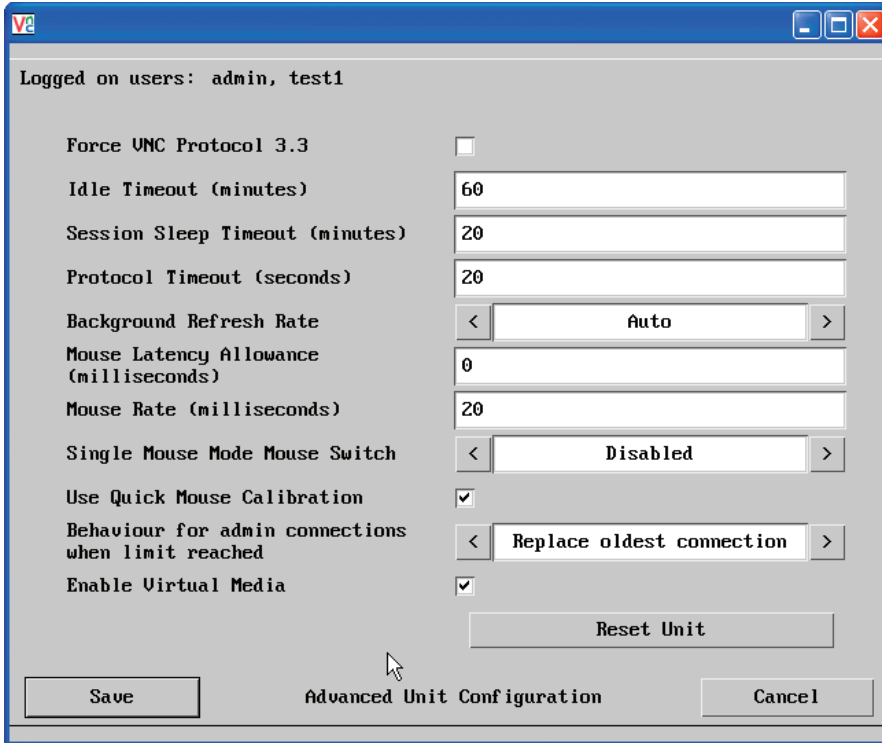

Force VNC Protocol 3.3

IMPORTANT: Protocol 3.3 is a legacy version that does not offer any encryption. Hashed passwords are not supported with 3.3

Idle Timeout

Determines the period of inactivity on a global connection before the user is logged out. The idle timeout period can be set to any time span, expressed in minutes.

Session Sleep Timeout

Determines the period of inactivity before the viewer screen will blank and a message is displayed. When no hosts are being viewed either because of this time out or if no viewers are active then parts of the video circuitry are powered down reducing power consumption by up to a third.

Protocol Timeout

Sets the time period by which responses should have been received to outgoing data packets. If the stated period is exceeded, then a connection is considered lost and terminated.

Background Refresh Rate

Use the arrow keys to alter the background refresh rate used to correct any screen changes missed in normal operation. The options are: Slow, Medium, Fast, Auto or Disabled. The Auto option automatically varies the refresh rate when multiple VNC sessions are active to provide a balance between the sessions.

Note: When a low connection speed is detected, the background refresh is automatically disabled, regardless of the settings of this option.

Mouse Latency Allowance

This option is used during calibration to account for latency delays that may be caused as signals pass through a device.

During calibration, the Agility Dual with VNC waits for 40ms after each mouse movement before sampling the next. If a device adds a significant delay to the flow of data, the calibration process can be lengthened or may fail entirely. The value entered here is added to (or subtracted from) the default 40ms sampling time.

Note: You can enter negative values (down to -40) in order to speed up the calibration process when using fast KVM switches. Use this option with caution as it can adversely affect the calibration process.

Mouse Rate

Defines the rate at which mouse movement data are transmitted to the system. The default option is 20ms, which equates to 50 mouse events per second. This is used to slow down the rate in exceptional circumstances but normally requires no adjustment.

Single Mouse Mode Mouse Switch

Select the mouse button combination to exit from single mouse mode (when active).

Use Quick Mouse Calibration

Invokes optimized calibration techniques that handle the majority of mouse types.

Behaviour for admin connections when limit reached

Determines what should occur when the limit on VNC users is reached. Options are: *Replace oldest connection*, *Replace newest connection* and *Don't replace*. Only non-administrator connections can be terminated in this way.

Enable Virtual Media

When ticked, allows the Virtual Media features to be used.

Reset Unit

Performs a complete cold boot of the Agility Dual with VNC unit.

Time & date configuration

This page allows you to configure all aspects relating to time and date within the unit.

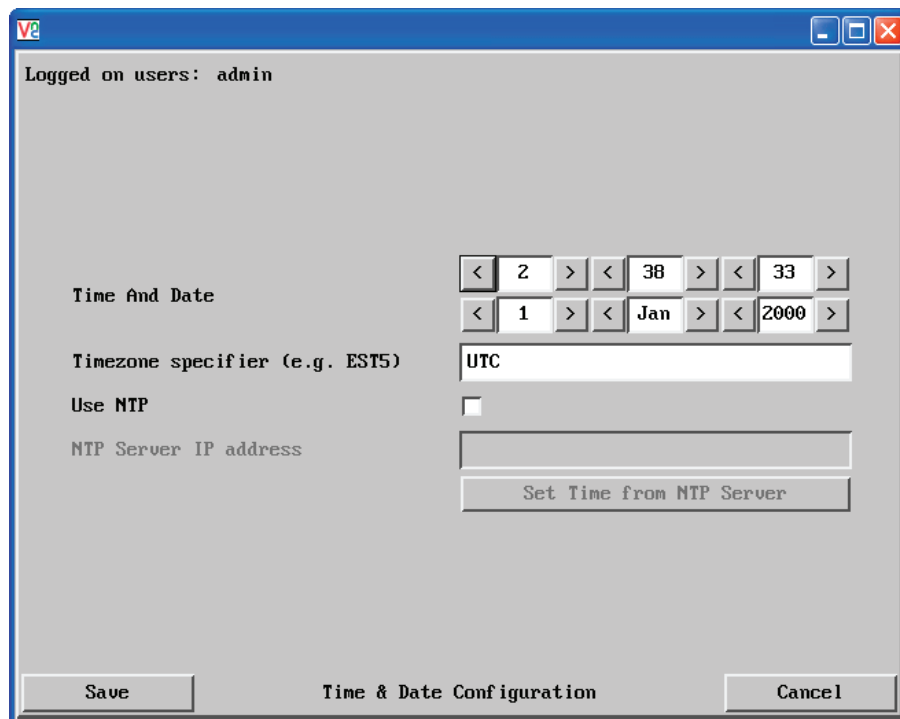

The screenshot shows a window titled "Time & Date Configuration" with a blue title bar and standard Windows window controls. The window content is as follows:

- Top left: "Logged on users: admin"
- Time And Date: A digital clock display showing "2:38:33".
- Timezone specifier (e.g. EST5): A dropdown menu currently set to "UTC".
- Use NTP: An unchecked checkbox.
- NTP Server IP address: An empty text input field.
- Below the IP address field: A button labeled "Set Time from NTP Server".
- Bottom left: A "Save" button.
- Bottom center: The window title "Time & Date Configuration".
- Bottom right: A "Cancel" button.

Use NTP

When this option is selected, the Agility Dual with VNC will synchronize its internal clocks using information from the (Network Time Protocol) server listed in the *NTP Server IP address* field.

NTP Server IP address

Optionally enter the IP address for a known Network Time Protocol server.

Set Time from NTP Server

Click to immediately use the time and date information from the listed NTP server.

Timezone specifier

Optionally enter a recognised timezone specifier related to the current position of the Agility Dual with VNC unit. When an NTP server is used, the specifier will be used to provide the correct real time.

The timezone specifier takes the following form:

std offset dst [offset], start[/time], end[/time]

The *std* and *offset* specify the standard time zone, such as GMT and 0, or CET and -1, or EST and 5, respectively.

The *dst* string and *[offset]* specify the name and offset for the corresponding Daylight Saving Time zone; if the *offset* is omitted, it defaults to one hour ahead of standard time.

The remainder of the specification describes when Daylight Saving Time is in effect. The *start* field is when Daylight Saving Time goes into effect and the *end* field is when the change is made back to standard time. The most common format used for the daylight saving time is: *m.w.d*

Where: *m* specifies the month and must be between **1** and **12**. The day *d* must be between **0** (Sunday) and **6**. The week *w* must be between **1** and **5**; week **1** is the first week in which day *d* occurs, and week **5** specifies the *last d* day in the month.

The *time* fields specify when, in the local time currently in effect, the change to the other time occurs. If omitted, the default is **02:00:00**.

Typical examples are:

UK:	GMT0BST,M3.5.0/1,M10.5.0/2
Central Europe:	CET-1CEST,M3.5.0/2,M10.5.0/3
US Eastern:	EST5EDT,M3.2.0/2,M11.1.0/2
US Pacific:	PST5PDT,M3.2.0/2,M11.1.0/2

For further details

- For details of timezone specifier formats, please refer to:
http://www.gnu.org/software/libc/manual/html_node/TZ-Variable.html
- For details of the Network Time Protocol (main RFC number: 1305; the SNTP subset used as the basis for the Agility Dual with VNC: 4330)
<http://www.ietf.org/rfc.html>

Network configuration

This page allows you to configure the various aspects of the IP port.

Logged on users: admin, test1

MAC address: 00:0F:58:01:94:99

IP Address	192.168.1.42
IP Network Mask	255.255.0.0
IP Gateway	192.168.1.1

VNC Port: 5900

HTTP Port (0=disabled): 80

IP Access Control

Add Remove Up Down Edit

+0.0.0.0/0.0.0.0

Save Network Configuration Cancel

MAC address

Media Access Control address – this is the unique and unchangeable code that was hard coded within your Agility Dual with VNC unit when it was built. It consists of six 2-digit hexadecimal (base 16) numbers separated by colons. A section of the MAC address identifies the manufacturer, while the remainder is effectively the unique electronic serial number of your particular unit.

IP Address

This is the identity of the Agility Dual with VNC within a network. The IP address can be thought of as the telephone number of the Agility Dual with VNC. Unlike the MAC address, the IP address can be altered to suit the network to which it is connected. It can either be entered manually or configured automatically using the DHCP option. When the DHCP option is enabled, this entry is grayed out.

IP Network Mask

Also often called the subnet-mask, this value is used alongside the IP address to help define a smaller collection (or subnet) of devices on a network. In this way a distinction is made between locally connected devices and ones that are reachable elsewhere, such as on the wider Internet. This process helps to reduce overall traffic on the network and hence speed up connections in general.

IP Gateway

This is the address of the device that links the local network (to which the Agility Dual with VNC is connected) to another network such as the wider Internet. Usually the actual gateway is a network router and it will be used whenever a required address lies outside the current network.

VNC Port

This is the logical link through which communications with a remote VNC viewer will be channelled. The default setting is 5900 which is a widely recognised port number for use by VNC software. However, in certain circumstances it may be advantageous to alter this number - see 'Security issues with ports' for more details.

HTTP Port

This is the logical link through which communications with a remote web browser will be channelled. The default setting of 80 is an established standard for web (HTTP – HyperText Transfer Protocol) traffic though this can be changed to suit your local network requirements.

IP Access Control

This section allows you to optionally specify ranges of addresses which will or won't be granted access to the Agility Dual with VNC. If this option is left unchanged, then the default entry of '+0.0.0.0/0.0.0.0' ensures that access from all IP addresses will be permitted. See [Setting IP access control](#) for details.

Setting IP access control

The golden rule with this feature is 'Include before you exclude' or to put it another way 'Arrange *allowed* addresses in the list before the *denied* addresses'.

This is because the positions of entries in the list are vitally important. Once a range of addresses is denied access, it is not possible to make exceptions for particular addresses within that range. For instance, if the range of addresses from A to F are denied access first, then the address C could not be granted access lower down the list. Address C needs to be placed in the list before the denied range.

IMPORTANT: This feature should be configured with extreme caution as it is possible to deny access to everyone. If such an error occurs, you will need to perform a [reset to factory default settings](#) in order to regain access.

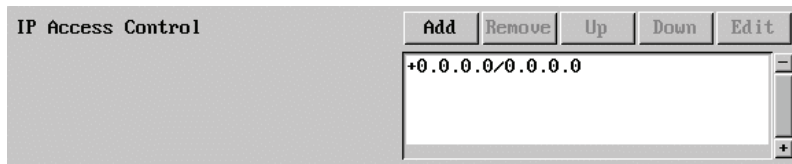

In the list, access control addresses prefixed by '+' are allow entries while those prefixed by '-' are deny entries.

To define a new IP access control entry

1 Click the Add button to display a popup dialog:

Network/Address

Enter the network address that is to be allowed or denied access. If a range of addresses is being specified then specify any one of the addresses within the range and use the Mask entry to indicate the size of the range.

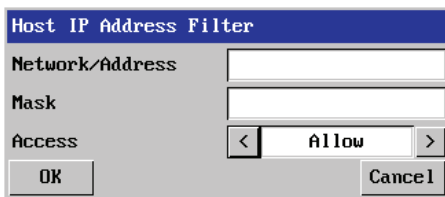

Mask

Enter an IP network mask that indicates the range of addresses that are to be allowed or denied access. For instance, if only a single specified IP address were to be required, the mask entry would be 255.255.255.255 in order to specify a single location.

Access

Use the arrow buttons to select either 'Allow' or 'Deny' as appropriate.

2 Enter the base network address, the mask and select the appropriate access setting.

3 Click the OK button.

To reorder access control entries

IMPORTANT: When reordering, ensure that any specific allowed addresses are listed higher in the list than any denied addresses. Take care not to invoke any deny access settings that would exclude valid users.

1 In the access control list, click on the entry to be moved.

2 Click the Up or Down buttons as appropriate.

To edit/remove access control entries

1 In the access control list, click on the appropriate entry.

2 Click either the Edit or Remove button as appropriate.

Serial port configuration

This page allows you to configure the baud rate of the Agility Dual with VNC serial port that is used to control power switch devices. A full range of standard baud rates are available.

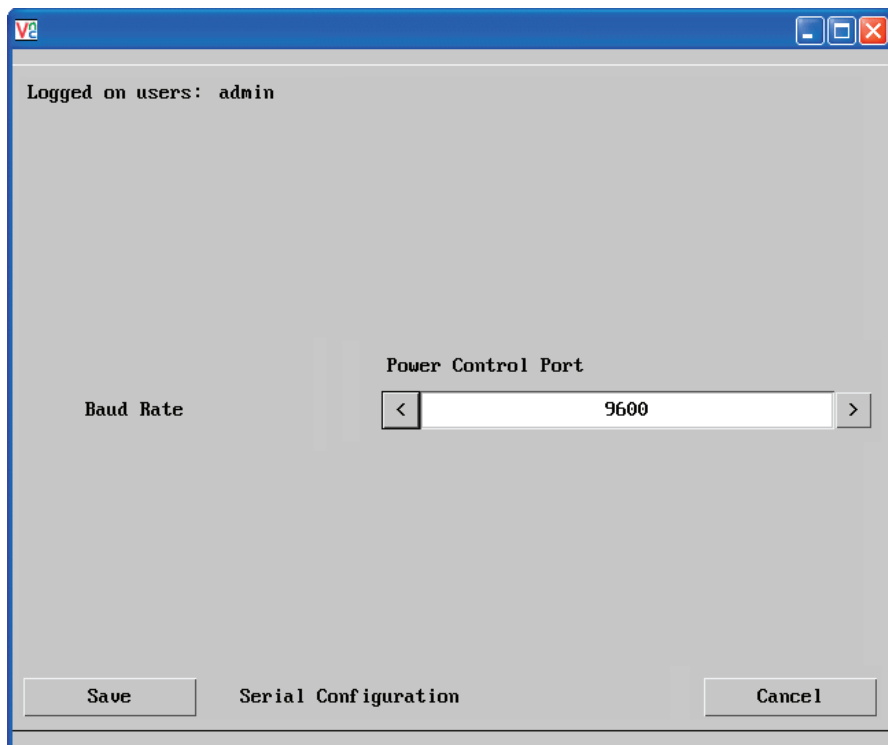

Baud Rate

Determines the communication speed of the OPTIONS port. The other communication settings are fixed as: No parity, 8 bit word, 1 stop bit.

Host configuration

This page provides the opportunity to configure various details for each of the host systems that may be connected to the Agility Dual with VNC. Each entry can be configured with a name, the permitted users, the hot key combinations required to switch to it and, if required, appropriate power control commands.

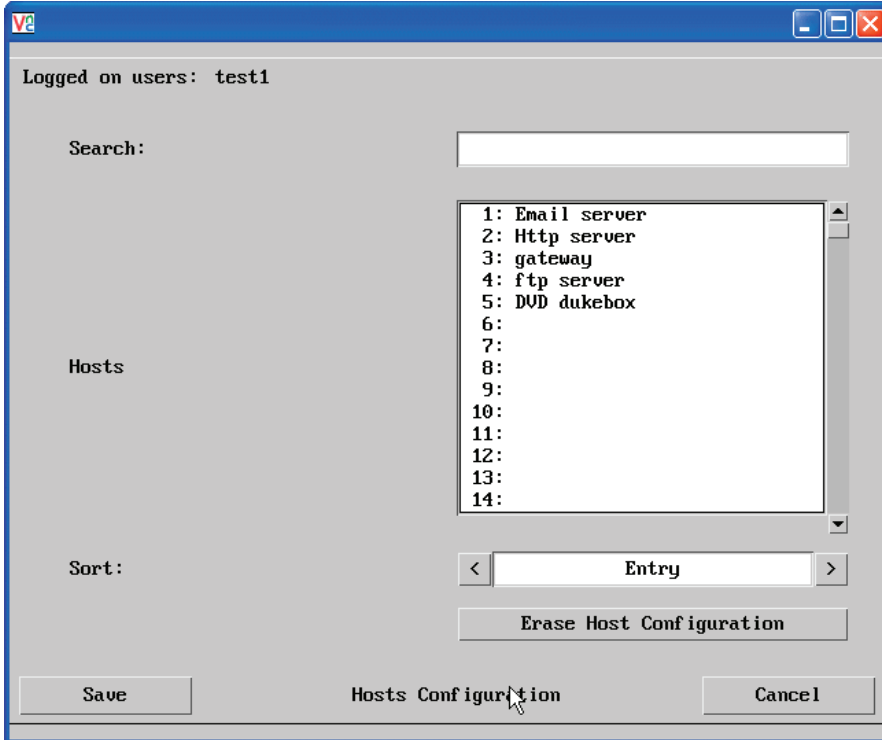

Sort

Allows you to reorder the list of hosts either alphabetically or by entry number.

Erase Host Configuration

Removes all hosts from the list.

To create a new host entry

- 1 Click one of the host entries to reveal a Host configuration dialog.

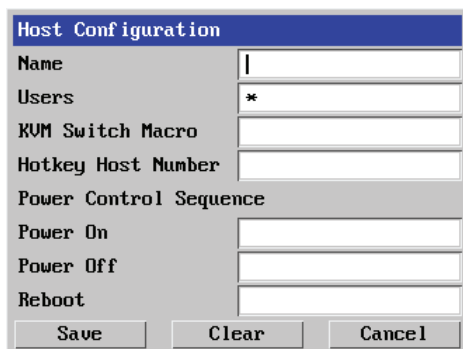

The image shows a 'Host Configuration' dialog box with the following fields and buttons:

Host Configuration	
Name	<input type="text"/>
Users	<input type="text" value="*"/>
KVM Switch Macro	<input type="text"/>
Hotkey Host Number	<input type="text"/>
Power Control Sequence	
Power On	<input type="text"/>
Power Off	<input type="text"/>
Reboot	<input type="text"/>
<input type="button" value="Save"/> <input type="button" value="Clear"/> <input type="button" value="Cancel"/>	

Name

Enter the name that will be displayed in the viewer window when you click the Host button.

Users

Select the users that will be permitted to connect to this host. Either enter * to allow all users or a list of users separated by commas.

KVM Switch Macro

Declare the hot key sequence that will cause the KVM switch to link with the required host system.

Hotkey Host Number

Declare the numeric sequence that is pressed together with the VNC viewer hotkeys (usually Ctrl + Alt) to select this host system, which is the same value as the KVM port number.

Power On

Enter the code required to make an attached power control unit apply power to the host. See [Power switching configuration](#) for details.

Power Off

Enter the code required to make an attached power control unit remove power from the selected host.

Reboot

Enter the code required to make an attached power control unit remove power and then re-apply it a few seconds later.

- 2 Enter the required information in each field.
- 3 Click the OK button.

Power switching configuration

Power switch configuration comprises two main steps:

- Configure the OPTIONS serial port to the same speed as used by the power switch box(es), using the [Serial port configuration menu](#).
- Configure power ON and OFF strings for each relevant host computer.

For each power port there needs to be a valid 'Power ON string' and similarly an appropriate 'Power OFF string'. In each case, the strings are a short sequence of characters that combine a port address and a power on or off value.

If a particular computer has more than one power input (and thus requires an equivalent number of power ports to control them), collections of strings can be combined to switch all of the required ports together as a group.

To configure the power sequences for each host computer

- 1 Using VNC viewer or a browser, log on as the 'admin' user.
- 2 Click the 'Configure' button in the top right corner.
- 3 Click the 'Host configuration' option.
- 4 Click a host entry to display a Host configuration dialog:

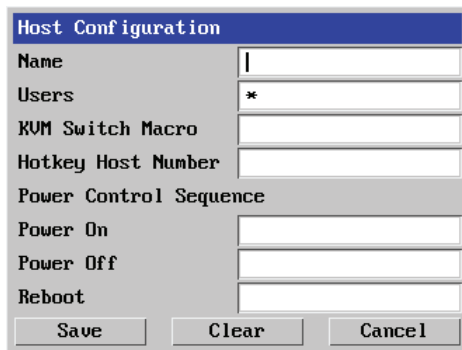

The image shows a 'Host Configuration' dialog box with the following fields and buttons:

Name	<input type="text"/>
Users	<input type="text" value="*"/>
KVM Switch Macro	<input type="text"/>
Hotkey Host Number	<input type="text"/>
Power Control Sequence	
Power On	<input type="text"/>
Power Off	<input type="text"/>
Reboot	<input type="text"/>
<input type="button" value="Save"/> <input type="button" value="Clear"/> <input type="button" value="Cancel"/>	

- 5 If necessary, configure other parameters (Name, Users, Hot Keys - [MORE](#)).
- 6 Enter the required **Power control sequences** in the Power On, Power Off and Reboot fields.
- 7 Click OK to close the dialog and then click the Save button in the main Host Configuration window to store the details.

Logging and status

This screen provides various details about the user activity on the Agility Dual with VNC unit.

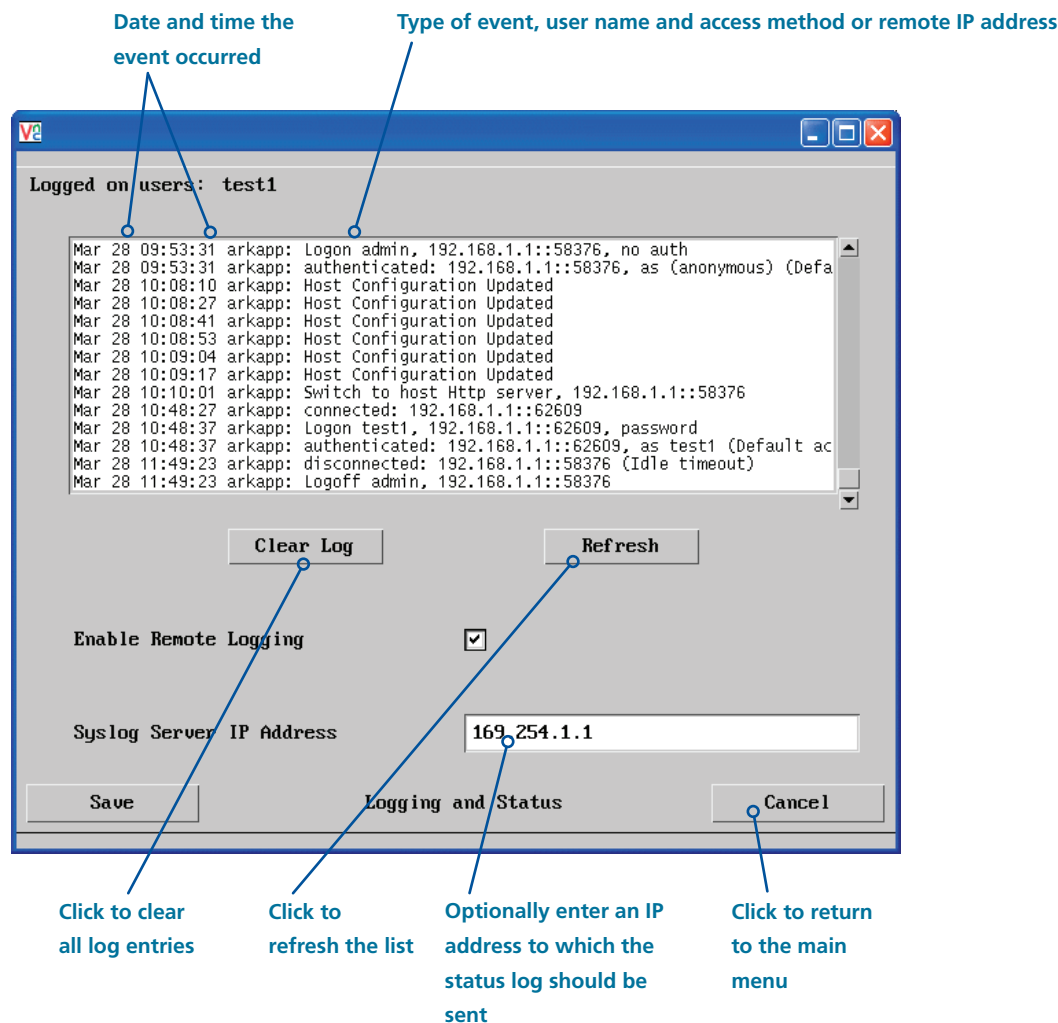

To copy and paste the log

You can copy the information listed within the log and paste it into another application.

- 1 While viewing the log screen, press Ctrl and C, to copy the data into the clipboard.
- 2 In a text application (i.e. Word, WordPad, Notepad) press Ctrl and V, or right mouse click and 'Paste'.

Syslog Server IP Address

Logging information can optionally be sent, as it occurs, to a separate system using the standard Syslog protocol. Enter the IP address of a suitable system in the field provided.

For further details

- For details of the Syslog protocol (RFC number: 3164) <http://www.ietf.org/rfc.html>

Appendix B. VNC viewer window options

Click the VNC icon in the top left corner of the viewer window (or press F8) to display the window options:

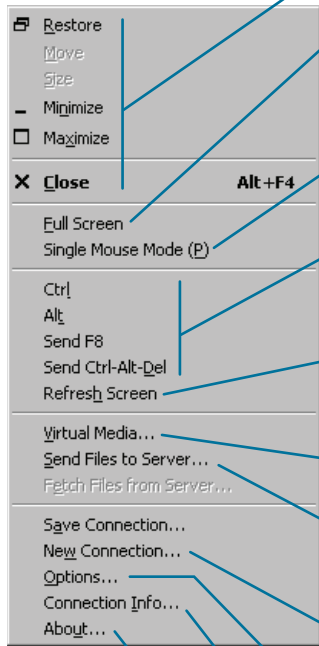

The screenshot shows a menu with the following items: Restore, Move, Size, Minimize, Maximize, Close (Alt+F4), Full Screen, Single Mouse Mode (P), Ctrl, Alt, Send F8, Send Ctrl-Alt-Del, Refresh Screen, Virtual Media..., Send Files to Server..., Fetch Files from Server..., Save Connection..., New Connection..., Options..., Connection Info..., and About... Blue lines connect each item to its corresponding description on the right.

- Standard window control items**
- Full screen**
Expands the VNC viewer window to fill the whole screen with no visible window edges or toolbar. Press F8 to re-display this menu.
- Single mouse mode (P)**
Used for fast network connections where a second, “predictor” cursor is not required.
- Ctrl, Alt, Send F8, Send Ctrl-Alt-Del**
Sends the selected keypress(es) to the Agility Dual with VNC and host computer. This is necessary because certain keys and key combinations are trapped by the VNC viewer.
- Refresh Screen**
Requests data from the server for a complete redraw of the screen image, not just the items that change.
- Virtual Media...**
Allows files to be transferred from the remote computer to the host.
- Send Files to Server...**
Allows files to be transferred from the remote computer to the host.
- New connection...**
Displays the connection dialog so that you can log on to a different Agility Dual with VNC or VNC server location.
- Options...**
Displays the full range of connection options.
- Connection info...**
Displays various connection and display details.
- About...**
Displays information about your VNC viewer.

Appendix C. The KVMADMIN utility

Particularly useful for complex Agility Dual with VNC configurations and the control of remote installations, KVMADMIN is a powerful administration tool.

KVMADMIN is based upon the established VNC viewer and uses the same security system. Rather than a graphical interface such as the standard viewer, KVMADMIN uses command line control to provide the following administration facilities:

- Discover and adjust the Agility Dual with VNC configuration, including host systems,
- Save and restore the Agility Dual with VNC configuration,
- Set user names and passwords,
- Download the event log,

The use of KVMADMIN is strictly limited to the 'admin' user and for security purposes it is not possible to retrieve user names or passwords from the Agility Dual with VNC.

To use KVMADMIN you require the IP address and admin password of the Agility Dual with VNC unit. The command line is as follows:

```
kvmadmin <command> <ip address> [<parameters>]
```

where <command> is one of the following:

- -setconfig <config-file>
- -getconfig <config-file>
- -setusers <csv-file>
- -getlog <log-file>
- -gethosts <csv-file>
- -sethosts <csv-file>
- -setmodes <csv-file>

For instance, the command line:

```
kvmadmin -getconfig kvm1.cfg 192.168.2.1
```

... downloads the current configuration from the Agility Dual with VNC unit at the given address and stores it in the local file *kvm1.cfg*.

Whereas the command line:

```
kvmadmin -setusers users.csv 192.168.2.1
```

... configures the usernames and passwords for the same unit from the local file *users.csv*.

For more information about KVMADMIN, please refer to the user notes supplied with the utility.

Appendix D. Java viewer options

When you are connecting to the Agility Dual with VNC using the Java viewer, a number of options are available.

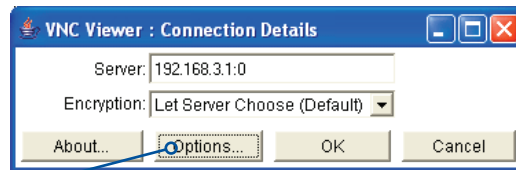

Click here to access the options

There are four options pages:

Encoding and color level

Auto select

When ticked, this option will examine the speed of your connection to the Agility Dual with VNC and apply the most suitable encoding method. This option is suggested for the majority of installations.

Preferred encoding

There are three manually selectable encoding methods which are accessible when the Auto select option is unticked.

- **ZRLE** – This is a highly compressed method that is best suited to slow modem connections.
- **Hextile** – This method offers better performance than the ZRLE when used over a high speed network because there is no need for the Agility Dual with VNC to spend time highly compressing the data.
- **Raw** – This is a primitive, uncompressed method that is mainly used for technical support issues. You are recommended not to use this method.

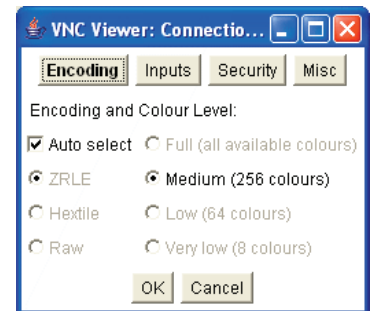

Color level

The color level is fixed at Medium (256 colors) for almost all browsers.

Inputs

View only (ignore mouse & keyboard)

When ticked, the viewer will not send keyboard or mouse information to the Agility Dual with VNC or host computer.

Accept clipboard from server

This feature is restricted to software server versions of VNC and has no effect on Agility Dual with VNC installations.

Send clipboard to server

This feature is restricted to software server versions of VNC and has no effect on Agility Dual with VNC installations.

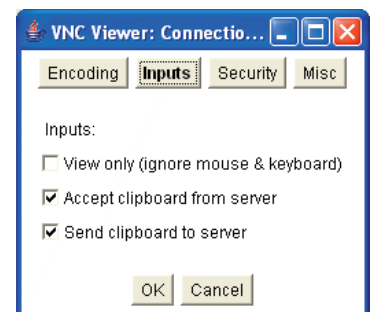

Security

512 bits (low security)

Selects the lowest level of encoding for communications between the browser and the Agility Dual with VNC.

1024 bits (medium security)

Selects the middle level of encoding for communications between the browser and the Agility Dual with VNC.

2048 bits (high security)

Selects the highest level of encoding for communications between the browser and the Agility Dual with VNC.

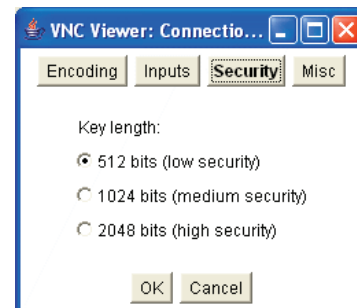

Misc

Shared (don't disconnect other viewers)

This feature is restricted to software server versions of VNC and has no effect on Agility Dual with VNC installations.

Render cursor locally

This feature is restricted to software server versions of VNC and has no effect on Agility Dual with VNC installations.

Fast CopyRect

This option should remain enabled.

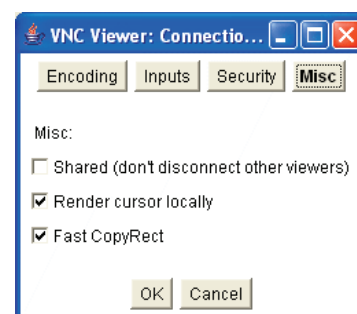

Appendix E. Hotkey sequences

Agility Dual with VNC allows you to enter commands suitable for any KVM switch in order to choose from up to 128 host systems. These switching commands can take the form of hotkey sequences that emulate standard keypress combinations.

Hotkey sequences

Almost any combination of keypresses can be emulated using the following notations:

- +** means press down the key that follows;
- means release the key that follows
- + -** means press and then release the key that follows
- *** means add a delay. The standard delay period is 250ms, however, if a number immediately follows the asterisk, this will define an alternate delay period (in milliseconds)

Notes

- The entries are not case sensitive.*
- All characters can be entered using their ASCII codes, from 32 to 126 (i.e. A,B,C, ... 1,2,3 etc.) with the exception of the special characters above.*
- It is not necessary to specify all keys to be released at the end because they are all released automatically after the last code.*
- A number of KVM switches from alternative manufacturers use hot key sequences that begin with a press/release of either the Scroll Lock or Ctrl keys. These often require a delay between the initial key press and the channel number to allow the switch to respond. A 500ms delay is usually sufficient.*

Examples

To send the command *Ctrl + Alt 4* you should use the following: `+Ctrl+Alt+4`.

To send the command *Ctrl + Alt 12* you should use the following: `+Ctrl+ALT+-1+2`
(the '+-1' entry causes the 1 key to be pressed and released before the 2 key is pressed).

To send the command *Scroll lock 1 + Enter* (with a 500ms delay) you should use the following: `+--Scr*500+1+Ent`

Main control keys (see 'Using abbreviations')

Backspace | Tab | Return | Enter | Ctrl | Alt | Win | Shift | LShift | RShift
LCtrl | RCtrl | LAlt | AltGr | RAlt | LWin | RWin | Menu | Escape | Space
CapsLock | NumLock | PrintScreen | Scrolllock

Math operand keys (see 'Using abbreviations')

Add (Plus) | Subtract (Minus) | Multiply

Central control keys (see 'Using abbreviations')

Insert | Delete | Home | End | PageUp | PageDown

Up | Down | Left | Right | Print | Pause

Keypad keys *(see 'Using abbreviations')*

KP_Insert | KP_Delete | KP_Home | KP_End | KP_PageUp

KP_PageDown | KP_Up | KP_Down | KP_Left | KP_Right | KP_Enter

KP_Add | KP_Subtract | KP_Divide | KP_Multiply

KP_0 to KP_9

Function keys

F1 | F2 | F3 | F4 | F5 | F6 | F7 | F8 | F9 | F10 | F11 | F12

Creating macro sequences

Hot key macro sequences can be up to 256 characters long. All keys are assumed to be released at the end of a line, however, you can also determine that a key is pressed and released within a sequence. Any of the following three examples will send a command that emulates and a press and release of the Scroll Lock key:

+SCROLL-SCROLL

+SCROLL

+SCROLL-

Example:

+SCROLL+SCROLL+1+ENTER

Press and release scroll twice, press 1 then enter then release all keys (equivalent definition is +SCROLL-SCROLL+SCROLL-SCROLL+1+ENTER-1-ENTER)

Using abbreviations

To reduce the length of the key definitions, any unique abbreviation for a key can be used. For example: "scroll", "scr" and even "sc" all provide an identifiable match for "ScrollLock" whereas "en" could not be used because it might mean "Enter" or "End" ("ent" would be suitable for "Enter").

Note: Hotkey sequences and abbreviations are not case sensitive.

Appendix F. Known working video modes

640x480 @ 60Hz

720x480 @ 60Hz

768x576 @ 60Hz

800x480 @ 60Hz

1024x600 @ 60Hz

1024x768 @ 60Hz

1152x768 @ 60Hz

1152x864 @ 60Hz

1280x720 @ 60Hz

1280x768 @ 60Hz

1280x800 @ 60Hz

1280x854 @ 60Hz

1280x960 @ 60Hz

1280x1024 @ 60Hz

1366x768 @ 60Hz

1400x1050 @ 60Hz

1440x900 @ 60Hz

1440x960 @ 60Hz

1600x900 @ 60Hz

1600x1200 @ 60Hz

1680x1050 @ 60Hz

1920x1080 @ 60Hz

1920x1200 @ 60Hz

2048x768 @ 60Hz

2048x1080 @ 60Hz

2048x1152 @ 60Hz

2048x1536 @ 60Hz

2048x2048 @ 60Hz

2560x1440 @ 60Hz

2560x1600 @ 60Hz

2560x2048 @ 50Hz

Appendix G. Mounting options

There are several main mounting methods:

- Via the (4) supplied self-adhesive rubber feet
- Via optional rack brackets
- Via the optional VESA mounting bracket

G.1 Rack Brackets

The optional brackets (plus four screws), enable the unit to be secured within a standard rack slot. See Figure G-1.

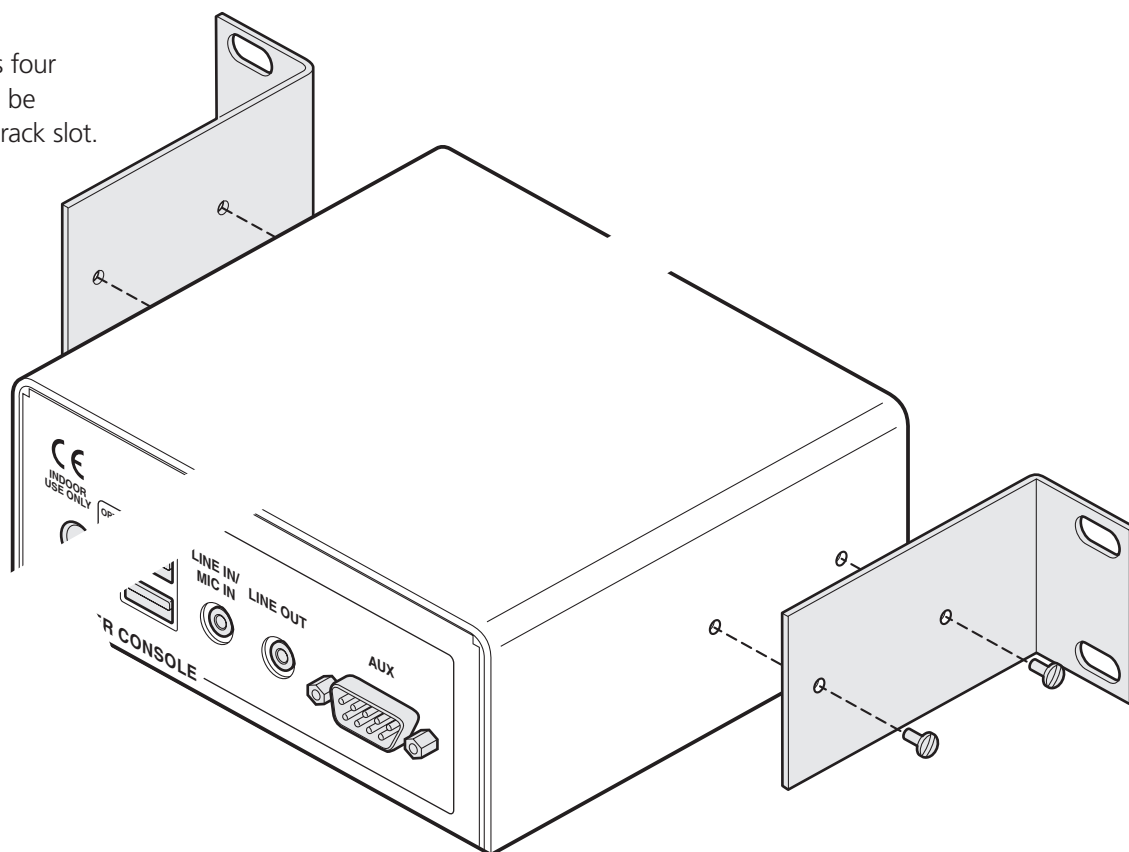

Figure G-1. Rackmount brackets.

IMPORTANT - allow space for airflow

ServSwitch Agility Dual VNC units and their power supplies generate heat when in operation and will become warm to the touch.

Do not place them in locations where air cannot circulate to cool the equipment. When mounting units within a rack chassis, allow a 1/3rd U space (1.5cm) between rows of devices:

Do not operate the equipment in ambient temperatures exceeding 104° F (40°C). Do not place the products in contact with equipment whose surface temperature exceeds 104° F (40°C).

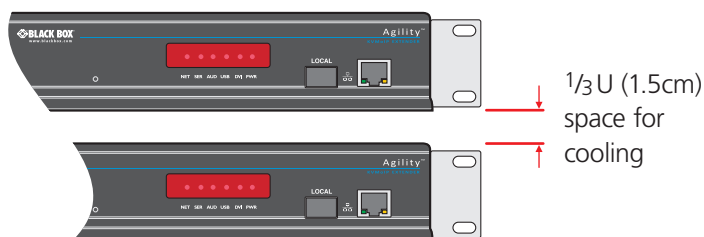

G.2 Using the VESA Mounting Bracket

The optional mounting bracket conforms to the VESA mounting standard and so can be used to mount a ServSwitch Agility unit directly to the rear of most video display units. The bracket can also be fixed directly to a wall or other solid surface using appropriate screws or bolts.

- 1 Orientate the bracket against the rear of the video display so that its small folded-in tabs are lowermost. See Figure G-2.

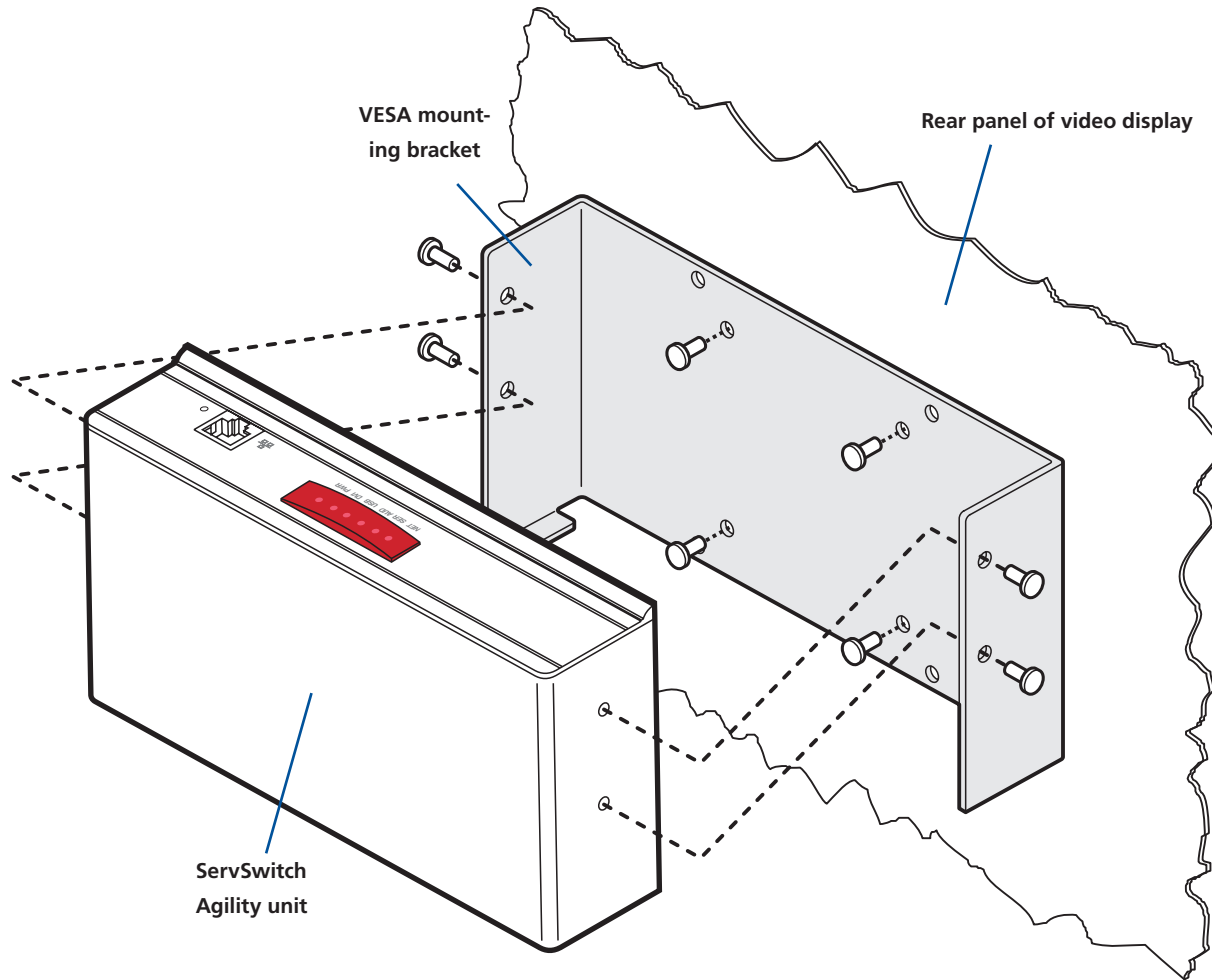

Figure G-2. VESA mounting bracket.

- 2 Attach the bracket to the video display using four screws of a size appropriate to the threaded holes within the video display panel - do not overtighten.
- 3 Place the Agility unit into the bracket with its base facing towards the video display and the front panel of the Agility unit facing upwards.
- 4 Secure the Agility unit to the bracket using the four supplied screws - do not overtighten.

Appendix H. Fiber modules and cables

To suit your installation layout, two fiber modules are available for the Agility Dual with VNC units to suit various fiber optic cables. The specifications for all are summarized in the table below:

Fiber Type	Fiber size	Fiber Type	Coding			Distance at 1Gbps	Bar color	Conn. type
			Normal Applications	Military Applications	Suggested Print Nomenclature			
OM1	(62.5/125)	Multimode (TIA-492AAAA)	Orange	Slate	62.5/125	220m	Black	LC
OM2	(50/125)	Multimode (TIA-492AAAB)	Orange	Orange	50/125	550m	"	"
OM3	(50/125)	Multimode (850 nm Laser-optimized) (TIA-492AAAC)	Aqua	Undefined	850 LO 50 /125	550m	"	"
OM4	(50/125)	Multimode (850 nm Laser-optimized) (TIA-492AAAC)	Aqua	Undefined	850 LO 50 /125	550m	"	"
OS1 and OS2	(9/125)	Single-mode (TIA-492C000 / TIA-492E000)	Yellow	Yellow	SM/NZDS, SM	10Km	Blue	LC

Appendix I. Safety Information

- For use in dry, oil free indoor environments only.
- The units and their power supplies generate heat when in operation and will become warm to the touch. Do not enclose them or place them locations where air cannot circulate to cool the equipment. Do not operate the equipment in ambient temperatures exceeding 40 degrees Centigrade. Do not place the products in contact with equipment whose surface temperature exceeds 40 degrees Centigrade.
- Warning - live parts contained within power adapter.
- No user serviceable parts within power adapter - do not dismantle.
- Plug the power adapter into a socket outlet close to the module that it is powering.
- Replace the power adapter with a manufacturer approved type only.
- Do not use the power adapter if the power adapter case becomes damaged, cracked or broken or if you suspect that it is not operating properly.
- If you use a power extension cord with a unit, make sure the total ampere rating of the devices plugged into the extension cord does not exceed the cord's ampere rating. Also, make sure that the total ampere rating of all the devices plugged into the wall outlet does not exceed the wall outlet's ampere rating.
- Do not attempt to service the units yourself.

Black Box Tech Support: FREE! Live. 24/7.

Tech support the
way it should be.



Great tech support is just 60 seconds away at 724-746-5500 or blackbox.com.



About Black Box

Black Box Network Services is your source for an extensive range of networking and infrastructure products. You'll find everything from cabinets and racks and power and surge protection products to media converters and Ethernet switches all supported by free, live 24/7 Tech support available in 60 seconds or less.

© Copyright 2015. Black Box Corporation. All rights reserved.

ACR1012A-T, rev. 3.4a