

## ADD-Q28ARS28CI-AOC7M

Arista Networks® AOC-Q-4S-100G-7M to Cisco® SFP-25G-AOC7M Compatible TAA Compliant 100GBase-AOC QSFP28 to 4xSFP28 Active Optical Cable (MMF, 850nm, 7m)

### Features

- QSFP28 and SFP28 MSA Compliant
- Four independent full-duplex channels
- Supports 103.1Gb/s aggregate bit rate
- 7m length
- Operating case temperature: 0 to 70°C
- Single 3.3V power supply
- 4 x 25G electrical interface (OIF CEI-28G-VSR) for QSFP28 terminal
- 25G electrical interface (OIF CEI-28G-VSR) for SFP28 terminal
- Maximum power consumption of 2.5W for QSFP28 terminal and 1.0W for each SFP28 terminal
- RoHS-6 compliant

### Applications

- 100G Ethernet
- InfiniBand EDR

### Product Description

This is an Arista Networks® AOC-Q-4S-100G-7M to Cisco® SFP-25G-AOC7M compatible 100GBase-AOC QSFP28 to 4xSFP28 active optical cable that operates over multi-mode fiber with a maximum reach of 7.0m (23.0ft). At a wavelength of 850nm, it has been programmed, uniquely serialized, and data-traffic and application tested to ensure it is 100% compliant and functional. This active optical cable is TAA (Trade Agreements Act) compliant, and is built to comply with MSA (Multi-Source Agreement) standards. We stand behind the quality of our products and proudly offer a limited lifetime warranty.

AddOn's active optical cables are RoHS compliant and lead-free.

TAA refers to the Trade Agreements Act (19 U.S.C. & 2501-2581), which is intended to foster fair and open international trade. TAA requires that the U.S. Government may acquire only "U.S. – made or designated country end products."



### Absolute Maximum Ratings

Parameter	Symbol	Min	Max	Units	Notes
Storage Temperature	T <sub>s</sub>	-40	85	degC	
Operating Case Temperature	T <sub>op</sub>	0	70	degC	
Power Supply Voltage	V <sub>cc</sub>	-0.5	3.6	V	
Relative Humidity (non-condensation)	RH	0	85	%	

### Recommended Operating Conditions and Power Supply Requirements

Parameter	Symbol	Min	Typical	Max	Units
Operating Case Temperature	T <sub>op</sub>	0		70	degC
Power Supply Voltage	V <sub>cc</sub>	3.135	3.3	3.465	
Data Rate, each Lane (QSFP8)			25.78125		
Data Rate, each Module (SFP28)			25.78125		
Data Rate Accuracy		-100		100	Ppm
Control Input Voltage High		2		V <sub>cc</sub>	V
Control Input Voltage Low		0		0.8	V

## QSFP28 Terminal Electrical Characteristics

Parameter	Test Point	Min.	Typical	Max	Units	Notes
Power Consumption				2.5	W	
Supply Current	I <sub>cc</sub>			757	mA	
<b>Transmitter (each lane)</b>						
Overload Differential Voltage pk-pk	TP1a	900			mV	
Common Mode Voltage (V <sub>cm</sub> )	TP1	-350		2850	mV	1
Differential Termination Resistant Mismatch	TP1			10	%	At 1MHz
Differential Return Loss (SDD11)	TP1			See CEI-28G-VSR Equation 13-19	dB	
Common Mode to Differential conversion and differential to common mode conversion (SDC11, SCD11)	TP1			See CEI-28G-VSR Equation 13-20	dB	
Stressed Input Test	TP1A	See CEI-28G-VSR Section 13.3.11.2.1				
<b>Receiver (each lane)</b>						
Differential Voltage pk-pk	TP4			900	mV	
Common Mode Voltage (V <sub>cm</sub> )	TP4	-350		2850	mV	1
Common Mode Noise, RMS	tP4			17.5	mV	
Differential Termination Resistance Mismatch	TP4			10	%	At 1MHz
Common Mode to Differential conversion and Differential to Common Mode conversion (SDC22, SCD22)	TP4			See CEI-28G-VSR Equation 13		
Common Mode Return Loss (SCC22)	TP4			-2	dB	2
Transition Time, 20 to 80%	TP4	9.5		5.5	dB	
Vertical Eye Closure (VEC)	TP4			5.5	dB	
Eye Width at 10 <sup>-15</sup> probability (EW15)	TP4	0.57			UI	
Eye Height at 10 <sup>-15</sup> probability (EH15)	TP4	228			mV	

### Notes:

1. V<sub>cm</sub> is generated by the host. Specification includes effects of ground offset voltage.
2. From 250MHz to 30GHz.

## SFP28 Terminal Electrical Characteristics

Parameter	Test Point	Min	Typical	Max	Units	Notes
Power Consumption				1.0	W	1
Supply Current	I <sub>cc</sub>			300	mA	1
<b>Transmitter</b>						
Overload Differential Voltage pk-pk	TP1a	900			mV	
Common Mode Voltage (V <sub>cm</sub> )	TP1	-350		2850	mV	2
Differential Termination Resistance Mismatch	TP1			10	%	At 1MHz
Differential Return Loss (SDD11)	TP1			See CEI- 28G-VSR Equation 13-19	B	
Common Mode to Differential conversion and Differential to Common Mode conversion (SDC11, SCD11)	TP1			See CEI- 28G-VSR Equation 13-20	dB	
Stressed Input Test	TP1a	See CEI- 28G-VSR Section 13.3.11.2.1				
<b>Receiver</b>						
Differential Voltage, pk-pk	TP4			900	mV	
Common Mode Voltage (V <sub>cm</sub> )	TP4	-350		2850	mV	2
Common Mode Noise, RMS	TP4			17.5	mV	
Differential Termination Resistance Mismatch	TP4			10	%	At 1MHz
Differential Return Loss (SDD22)	TP4			See CEI- 28G-VSR Equation 13-19	dB	
Common Mode to Differential conversion and Differential to Common Mode conversion (SDC22, SCD22)	TP4			See CEI- 28G-VSR Equation 13-21	dB	
Common Mode Return Loss (SCC22)	TP4			-2	dB	3
Transition Time, 20 to 80%	TP4	9.5			ps	
Vertical Eye Closure (VEC)	TP4			5.5	dB	
Eye Width at 10 <sup>-15</sup> probability (EW15)	TP4	0.57			UI	
Eye Height at 10 <sup>-15</sup> probability (EH15)	TP4	228			mV	

### Notes:

1. Per terminal.
2. V<sub>cm</sub> is generated by the host. Specification includes effects of ground offset voltage.
3. From 250MHz to 30GHz.

## QSFP28 Pin Descriptions

Pin	Logic	Symbol	Name/Descriptions	Notes
1		GND	Ground	1
2	CML-I	Tx2n	Transmitter Inverted Data Input	
3	CML-I	Tx2p	Transmitter Non-Inverted Data output	
4		GND	Ground	1
5	CML-I	Tx4n	Transmitter Inverted Data Input	
6	CML-I	Tx4p	Transmitter Non-Inverted Data output	
7		GND	Ground	1
8	LVTLL-I	ModSelL	Module Select	
9	LVTLL-I	ResetL	Module Reset	
10		VccRx	+3.3V Power Supply Receiver	2
11	LVC MOS-I/O	SCL	2-Wire Serial Interface Clock	
12	LVC MOS-I/O	SDA	2-Wire Serial Interface Data	
13		GND	Ground	
14	CML-O	Rx3p	Receiver Non-Inverted Data Output	
15	CML-O	Rx3n	Receiver Inverted Data Output	
16		GND	Ground	1
17	CML-O	Rx1p	Receiver Non-Inverted Data Output	
18	CML-O	Rx1n	Receiver Inverted Data Output	
19		GND	Ground	1
20		GND	Ground	1
21	CML-O	Rx2n	Receiver Inverted Data Output	
22	CML-O	Rx2p	Receiver Non-Inverted Data Output	
23		GND	Ground	1
24	CML-O	Rx4n	Receiver Inverted Data Output	1
25	CML-O	Rx4p	Receiver Non-Inverted Data Output	
26		GND	Ground	1
27	LVTTL-O	ModPrsL	Module Present	
28	LVTTL-O	IntL	Interrupt	
29		VccTx	+3.3 V Power Supply transmitter	2
30		Vcc1	+3.3 V Power Supply	2
31	LVTTL-I	LPMode	Low Power Mode	
32		GND	Ground	1
33	CML-I	Tx3p	Transmitter Non-Inverted Data Input	
34	CML-I	Tx3n	Transmitter Inverted Data Output	
35		GND	Ground	1

36	CML-I	Tx1p	Transmitter Non-Inverted Data Input	
37	CML-I	Tx1n Transmitter Inverted Data Output	Transmitter Inverted Data Output	
38		GND	Ground	1

**Notes:**

1. Gnd is the GND is the symbol for signal and supply (power) common for QSFP28 modules. All are common within the QSFP28 module and all module voltages are referenced to this potential unless otherwise noted. Connect these directly to the host board signal common ground plane.
2. VccRx, Vcc1 and VccTx are the receiving and transmission power suppliers and shall be applied concurrently. Recommended host board power supply filtering is shown in Figure 4 below. Vcc Rx, Vcc1 and Vcc Tx may be internally connected within the QSFP28 transceiver module in any combination. The connector pins are each rated for a maximum current of 1000mA.

**QSFP28 Connector Pin Layout**

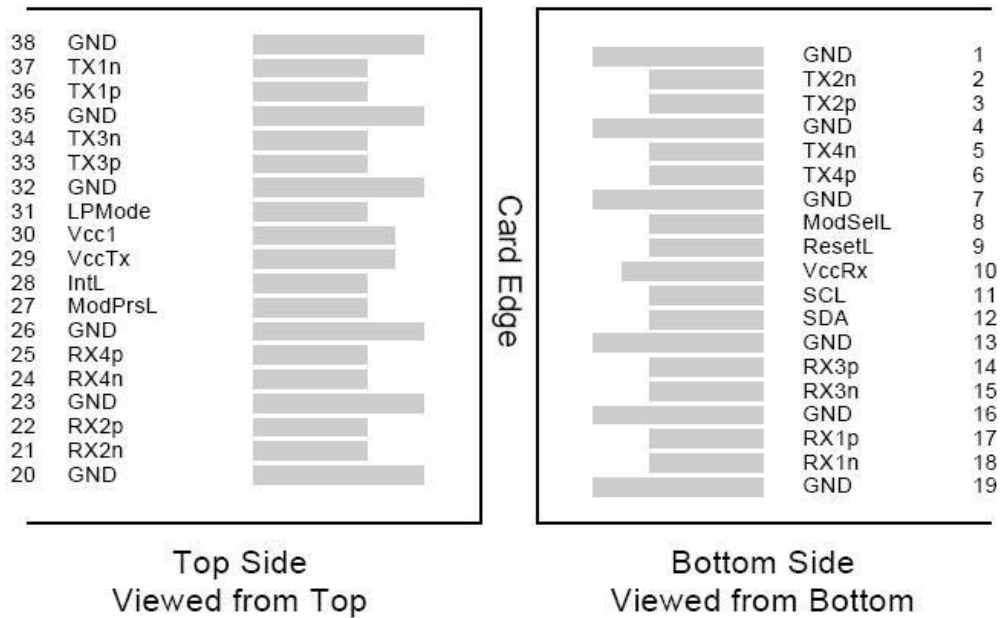

## SFP28 Pin Descriptions

Pin	Logic	Symbol	Name/Descriptions	Notes
1		VeeT	Module Transmitter Ground	1
2	LVTTL-O	TX_Fault	Module Transmitter Fault	
3	LVTTL-I	TX_Dis	Transmitter Disable; Turns off transmitter laser output	
4	LVTTL-I/O	SDA	2-Wire Serial Interface Data Line	2
5	LVTTL-I	SCL	2-Wire Serial Interface Clock	2
6		MOD_DEF0	Module Definition Grounded in the module	
7	LVTTL-I	RS0	Receiver Rate Select	
8	LVTTL-O	RX_LOS	Receiver Loss of Signal Indication Active LOW	
9	LVTTL-I	RS1	Transmitter Rate Select (not used)	
10		VeeR	Module Receiver Ground	1
11		VeeR	Module Receiver Ground	1
12	CML-O	RD-	Receiver Inverted Data Output	
13	CML-O	RD+	Receiver Data Output	
14		VeeR	Module Receiver Ground	1
15		VccR	Module Receiver 3.3 V Supply	
16		VccT	Module Receiver 3.3 V Supply	
17		VeeT	Module Transmitter Ground	1
18	CML-I	TD+	Transmitter Non-Inverted Data Input	
19	CML-I	TD-	Transmitter Inverted Data Input	
20		VeeT	Module Transmitter Ground	1

### Notes:

1. Module ground pins GND are isolated from the module case.
2. Shall be pulled up with 4.7K-10Kohms to a voltage between 3.15V and 3.45V on the host board.

### SFP28 Connector Pin Layout

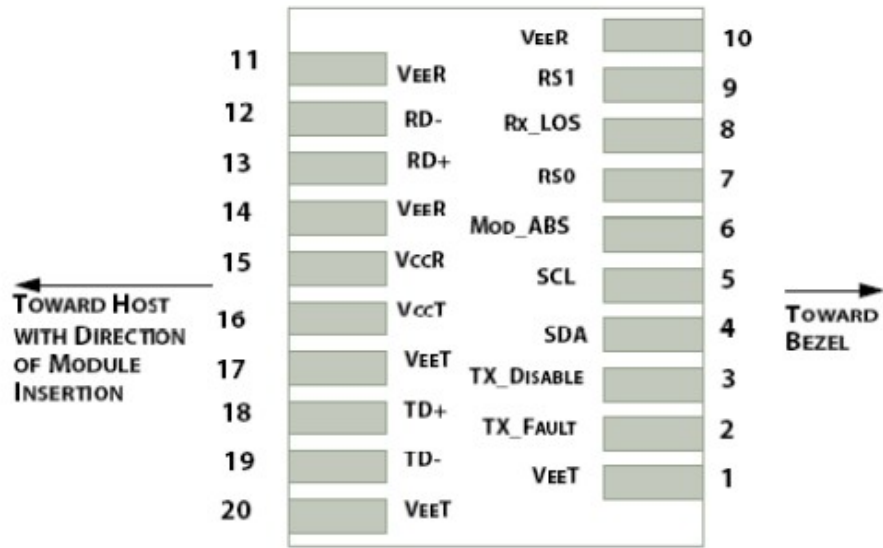

### Recommended Power Supply Filter for QSFP28 Terminal

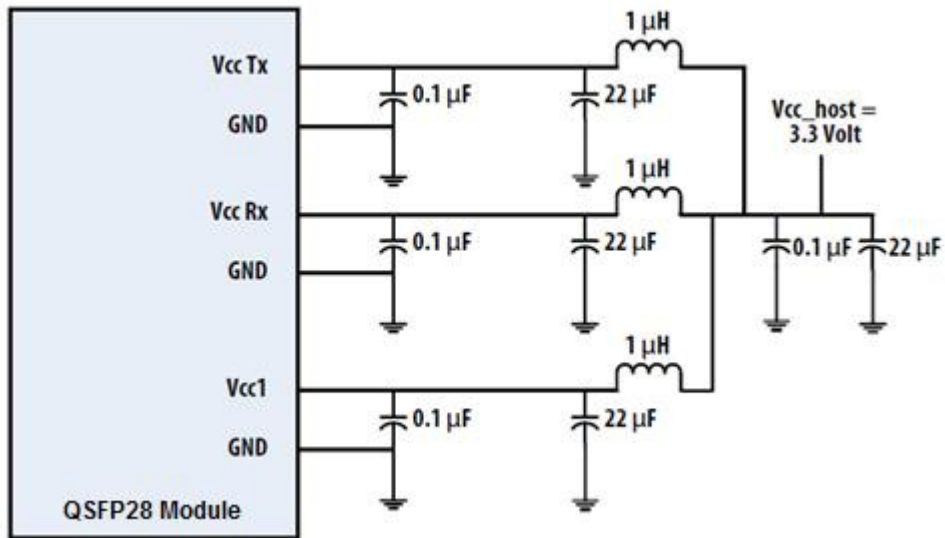



### Recommended Power Supply Filter for SFP28 Terminals

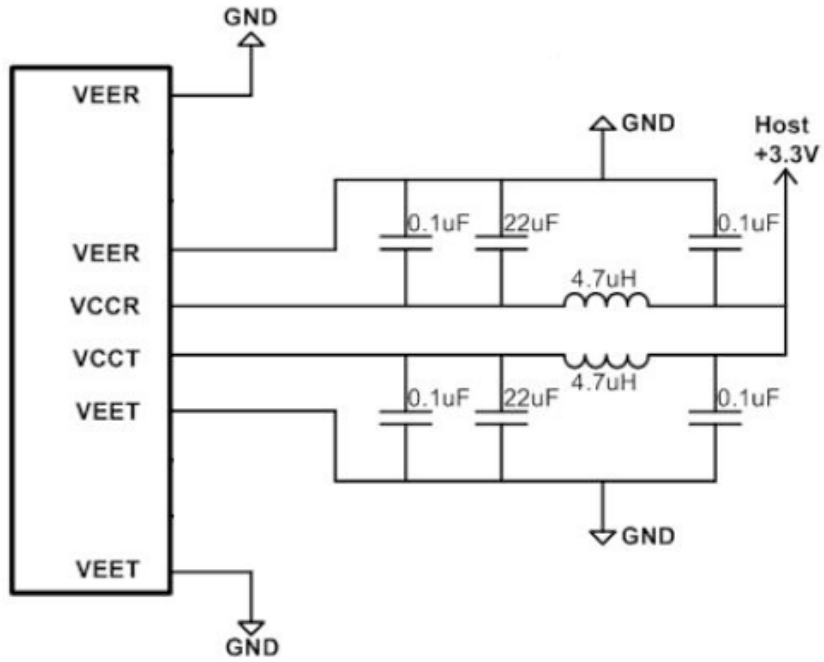

### QSFP28 Terminal Mechanical Specifications

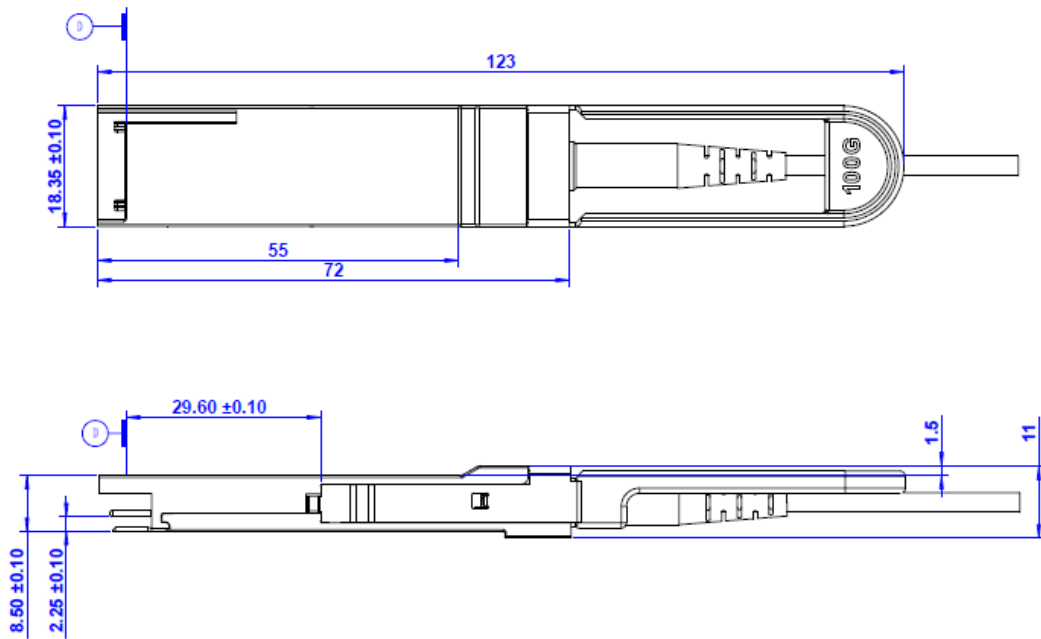

SFP28 Terminal Mechanical Specifications

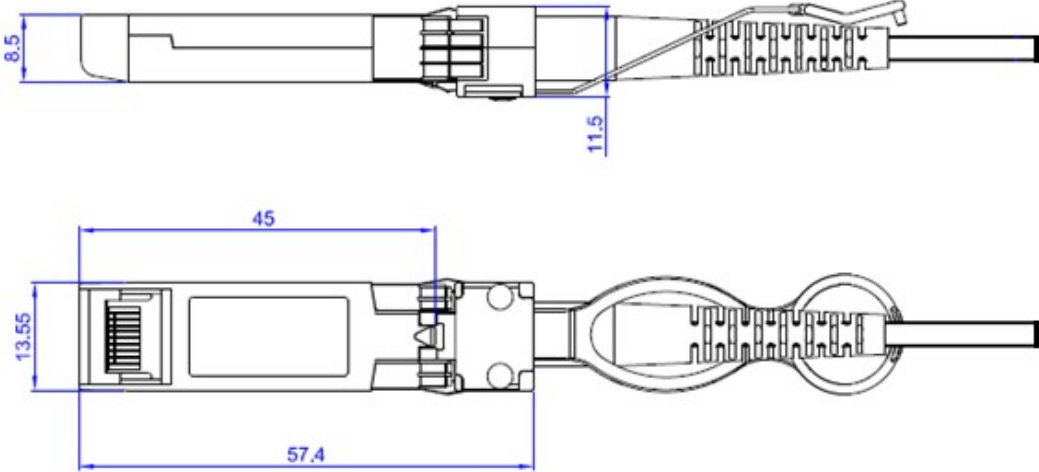

## **About AddOn Networks**

In 1999, AddOn Networks entered the market with a single product. Our founders fulfilled a severe shortage for compatible, cost-effective optical transceivers that compete at the same performance levels as leading OEM manufacturers. Adhering to the idea of redefining service and product quality not previously had in the fiber optic networking industry, AddOn invested resources in solution design, production, fulfillment, and global support.

Combining one of the most extensive and stringent testing processes in the industry, an exceptional free tech support center, and a consistent roll-out of innovative technologies, AddOn has continually set industry standards of quality and reliability throughout its history.

Reliability is the cornerstone of any optical fiber network and is engrained in AddOn's DNA. It has played a key role in nurturing the long-term relationships developed over the years with customers. AddOn remains committed to exceeding industry standards with certifications from ranging from NEBS Level 3 to ISO 9001:2005 with every new development while maintaining the signature reliability of its products.

## **U.S. Headquarters**

Email: [sales@addonnetworks.com](mailto:sales@addonnetworks.com)

Telephone: +1 877.292.1701

Fax: 949.266.9273

## **Europe Headquarters**

Email: [salesupportemea@addonnetworks.com](mailto:salesupportemea@addonnetworks.com)

Telephone: +44 1285 842070